

fischer 

UltraCut FBS II.
High-performance
concrete screw
for absolute
installation ease.



Concrete screw UltraCut FBS II. The assortment for a wide range of applications.



FBS II ZN-plated



FBS II 6 ZN-plated



FBS II CP



FBS II R



SC-ST



FSW

UltraCut FBS II

8, 10, 12 and 14 zinc-plated steel

The high-performance concrete screw for absolute installation ease in the interior area.

Unique saw-tooth geometry **cuts quickly into the concrete** – also in multiple use and reinforced concrete.

The UltraCut FBS II is available in different head designs. **Countersunk (SK) and hexagonal head (US)** with and without internal torx drive.



Through the special thread geometry, the screw flanks cut deeply into the concrete and allow **higher loads**. This **saves costs** because less anchor points and smaller base plates are required.

UltraCut FBS II 10x100 US

The short UltraCut FBS II, with a reduced embedment depth, allows for a **short drill hole depth, fast installation and less reinforcement hits** which makes it an efficient choice for many applications.



UltraCut FBS II 10x60 US

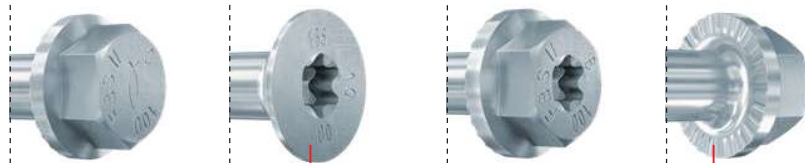

The countersunk head is suitable for **visually appealing installations**.

The ribs under the head prevent accidental loosening of the anchor making the system **more secure**.

Advantages and functions

Your advantages at a glance

- With up to 3 embedment depths, the UltraCut FBS II allows an optimal adaption to different applications / load requirements.
- Expansion-free anchoring (undercut) allows for lowest edge- and axial spacings.
- The assessment (ETA Option 1) covers the use of single-point anchors in cracked and non-cracked concrete.
- The performance categories seismic C1 and C2 ensure that the strictest of safety standards and earthquake specifications can be fulfilled.
- The approved adjustment for the concrete screws allows the screw to be unscrewed twice for a total length of 20 mm, to place maximum 10 mm packing below the base plate head or to align the attached part, and then to tighten the screw again.
- The concrete screws are also approved for multiple use in temporary fixings (e.g. inclined supports) after a verification with the checking gauge FUP. Also with young concrete 10 N/ mm².
- Drill holes do not need to be cleaned during vertical installation (ceiling and floor).
- The fischer concrete screw FBS II 8-10 offer the possibility for the ETA compliant application in masonry bricks. This grants high security not only in concrete but also in many other applications in other substrates (valid for the base materials solid clay bricks (EN771-1), sand-lime bricks KSL (EN711-2) and solid sand-lime bricks KSV (EN771-2) according to the specification of the ETA-20/0134).

Functioning

- The UltraCut FBS II is recommended for the push-through installation.
- The screw is installed correctly when the screw head sits flush on the fixture and cannot be screwed in deeper (visual setting control).
- Drill holes do not need to be cleaned during vertical installation (ceiling and floor). For floor fixings the hole must be drilled 3x drill hole diameter deeper.
- We recommend using a tangential impact wrench with a suitable impact wrench socket (e.g. fischer FSS 18V) or an internal torx drive.
- The assessment documents (ETA-15/0352, ETA-20/0321 and ETA-20/0134) also cover the use of hollow drills with automatic drill hole cleaning and the use of diamond drilling holes (except ETA-20/0134).
- The UltraCut FBS II US 8-14 as concrete-concrete connector is also suitable for the strengthening of existing concrete structures through a top concrete layer.
- For the installation in masonry, please follow the instruction guidelines in the packaging with the suitable torque setting (impact wrench levels).

Approvals



ETA-15/0352,
for cracked concrete



ETA-20/0321,
for cracked concrete.
Connector for strengthening of existing concrete structures through top concrete layer.



ETA-20/0134
for masonry



Temporary fixings



R 120



Seismic C2



According VdS CES-
Guidelines for sprinkler
systems

Recommendations

Suitable for building materials, such as



Cracked concrete



Uncracked concrete



Masonry brick*



Solid sand-lime brick*



Perforated sand-lime
brick*

* ETA approval for diameter 8 and 10

Installation

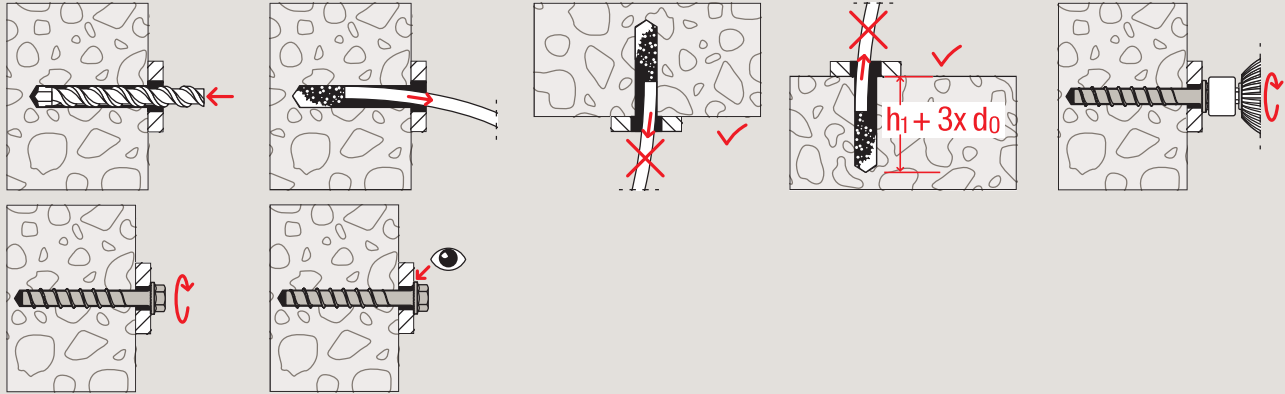

Fixture adjustment

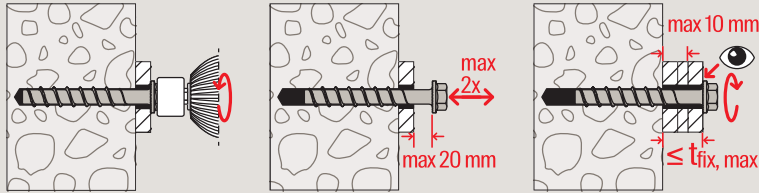

Annular gap filling,

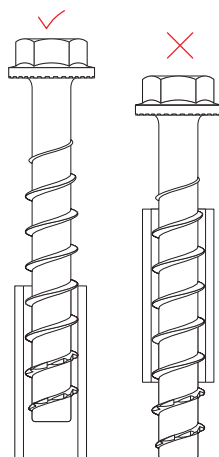
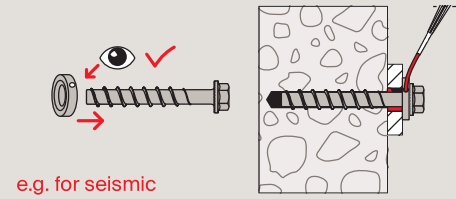

UltraCut FBS II for multiple use of temporary fixings

The FBS II can be used to install temporary construction site installations such as guardrails, inclined supports and frameworks in young concrete of 10 N/mm². Therefore the FBS II 8, 10, 12 and 14 made of galvanised zinc-plated steel are approved for temporary indoor and outdoor use. After dismantling, the fischer concrete screw FBS II can be reused. Depending on the concrete quality, ten or more applications of the same FBS II are possible. For this purpose the abrasion of the thread is examined with the corresponding checking gauge.

Applications



UltraCut FBS II 8,10,12 and 14

Metal construction



Railings

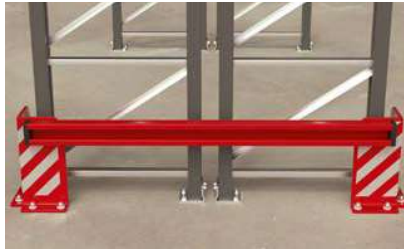

Shelving systems



Brackets / base plates

Formwork construction / site facilities



Inclined supports



Construction site installations in tunnels

Timber work



Step/rise anchorage



Beam anchorage

Sanitary, heating and electrical industry

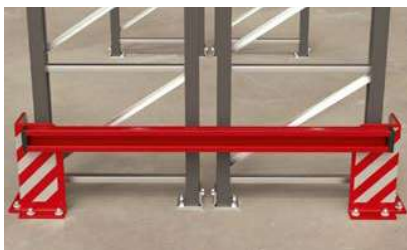

Suspended mounting channels



Diamond drilling equipment



Cable trays

UltraCut FBS II

6 zinc-plated steel

Different head designs offer a maximum of flexibility and a perfect adaptation to the application.



UltraCut FBS II 6 SK

The special double angle on the under-head geometry **increases the stability of the concrete screw** during screwing in.



UltraCut FBS II 6 P / LP

The design of the concrete screw with panhead and large panhead allows **aesthetic installation**.



UltraCut FBS II 6 US

The special head geometry for use in mounting rails (up to 17 mm slot width) with a socket (SW10) enables **simple installation of the add-on part**.



UltraCut FBS II 6 M8 or M10

The hanger bolt enables the **easy and suitable application of pipe clamps** and connecting elements.



UltraCut FBS II 6 M6 I, M8/M10 I

The design of the concrete screw with connection sleeve with step thread offers **maximum flexibility when mounting threaded rods** or connecting elements.



Advantages and functions

Your advantages at a glance

- The special ratio between flank and shaft diameter allows for a deep and fast cutting into the concrete.
- The ETA assessment option 1 includes the use in cracked and non-cracked concrete for highest safety requirements.
- The UltraCut FBS II 6 is approved for multiple use of non-load bearing systems and thereby ideal for the installation of pipe routes and prestressed hollow concrete ceilings.
- The first diameter 6 mm concrete screw with an ETA assessment for the C1 seismic performance category for additional safety standards.
- The approved adjustment for the concrete screws allows the screw to be unscrewed twice for a total length of 20 mm, to place maximum 10 mm packing below the screw head or to align the attached part, and then to tighten the screw again.
- Drill holes do not need to be cleaned during vertical installation (ceiling and floor).
- The fischer concrete screws FBS II 6-10 offer the possibility for the ETA compliant application in masonry brick. This grants high security not only in concrete but also in many other applications in other substrates (valid for the base materials solid clay bricks (EN771-1), sand-lime bricks KSL (EN711-2) and solid sand-lime bricks KSV (EN771-2) according to the specification of the ETA-20/0134.

Functioning

- The UltraCut FBS II 6 ZN-plated is recommended for the push-through and pre-positioned installation.
- The screw is installed correctly when the screw head sits flush on the fixture/substrate surface and cannot be screwed in deeper (visual setting control).
- We recommend using a tangential impact wrench with a suitable impact wrench socket (e.g. fischer FSS 18V) or an internal torx drive.
- For the installation in masonry, please follow the instruction guidelines in the packaging with the suitable torque setting (impact wrench levels).

Approvals



ETA-15/0352,
for cracked concrete



ETA-18/0242,
for non-structural
applications in
concrete



ETA-20/0134
for masonry



According VdS
CES-Guidelines for
sprinkler systems

Recommendations

Suitable for building materials, such as



Cracked concrete



Uncracked concrete



Masonry brick



Solid sand-lime brick



Perforated sand-lime
brick



Variable embedment depths (Multiple use of redundant systems)

Enables a flexible adaptation to the loads.

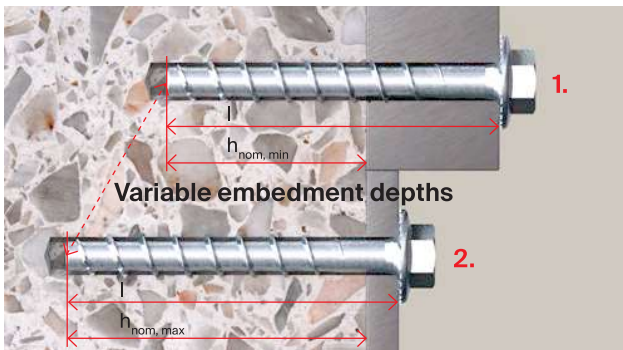

1. Fast installation due to minimum embedment depth
e.g. FBS II 6x60/5 US

- Minimum embedment depth is 25 mm
- Permissible tensile load at $h_{\text{nom, min}} = 25 \text{ mm}$ is 0.7 kN
- Permissible shear load at $h_{\text{nom, min}} = 25 \text{ mm}$ is 1.8 kN

2. Maximum load due to maximum embedment depth
e.g. FBS II 6x60/5 US

- Minimum embedment depth is 55 mm
- Permissible tensile load at $h_{\text{nom, max}} = 55 \text{ mm}$ is 4.0 kN
- Permissible shear load at $h_{\text{nom, max}} = 55 \text{ mm}$ is 6.3 kN

Installation and applications

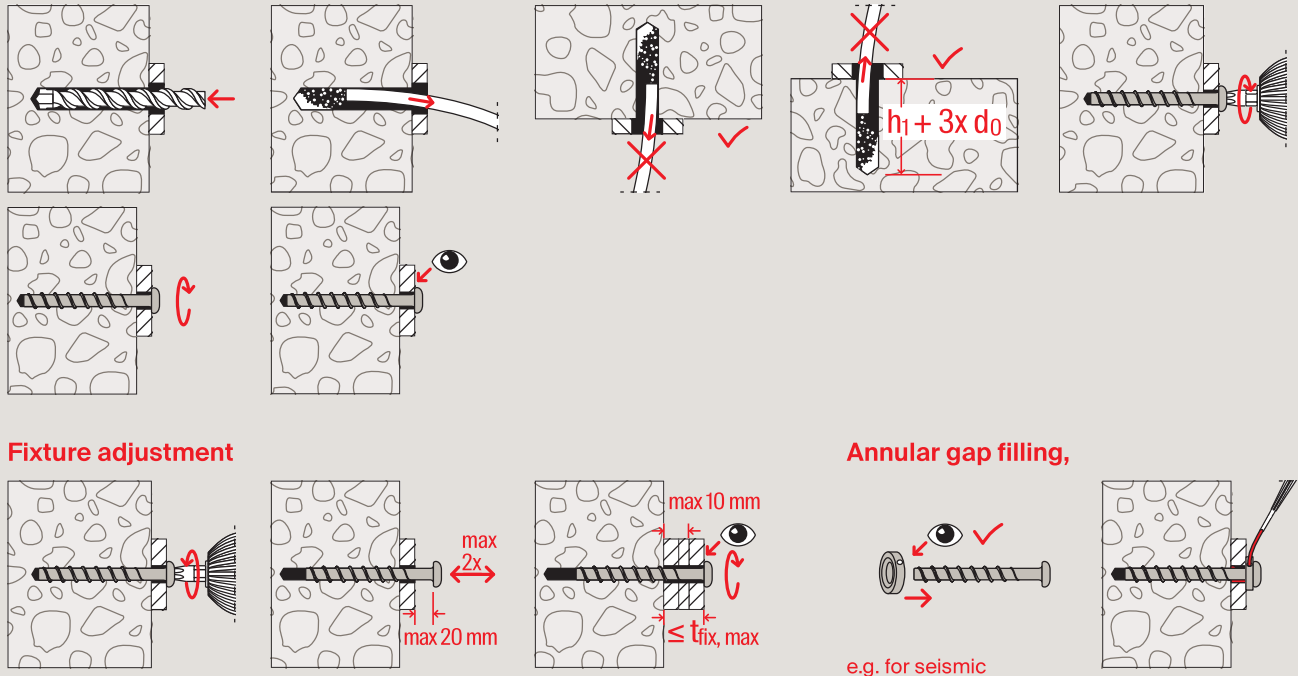

UltraCut FBS II 6

Sanitary, heating and electrical industry

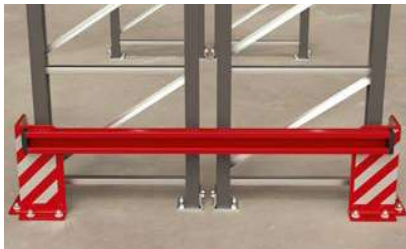

Mounting channels

e. g. UltraCut FBS II 6 US



Suspended mounting channels

e. g. UltraCut FBS II M8/19



Perforated tapes

e. g. UltraCut FBS II LP



Prestressed hollow concrete ceilings

e. g. UltraCut FBS II M8/M10 I



UltraCut FBS II

8, 10, 12 and 14 CP

The high-performance concrete screw for absolute installation ease with a special coating.

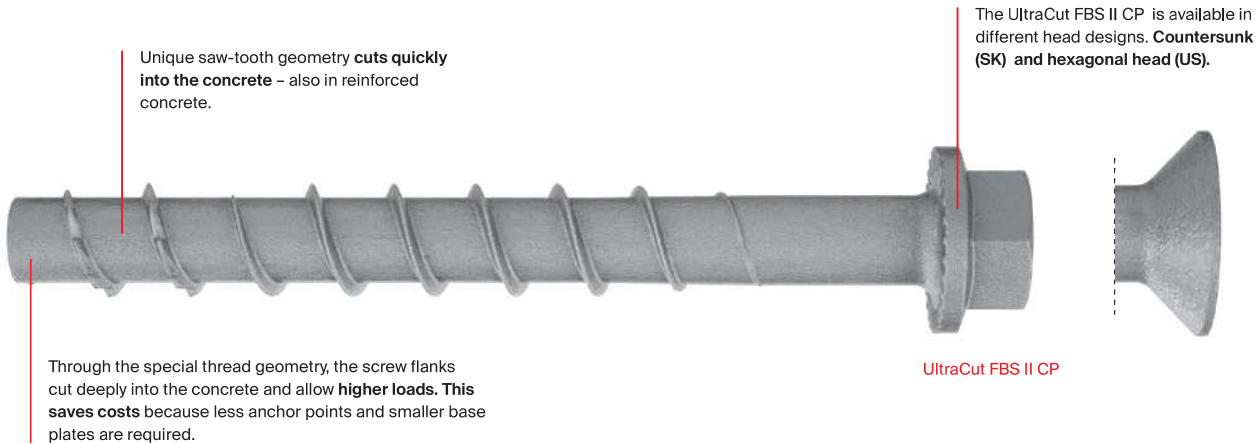

Tested and approved: High protection of the coating against red rust.

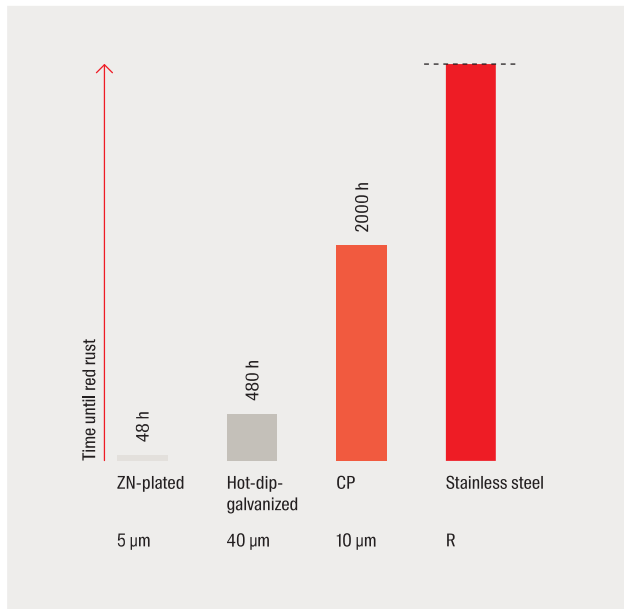

Salt spray chamber mist test

The UltraCut FBS II was developed in different coatings subjected to the salt spray chamber mist test according to DIN EN ISO 9227. The result is that the UltraCut FBS II CP coating withstands at least 2,000 h without red rust.

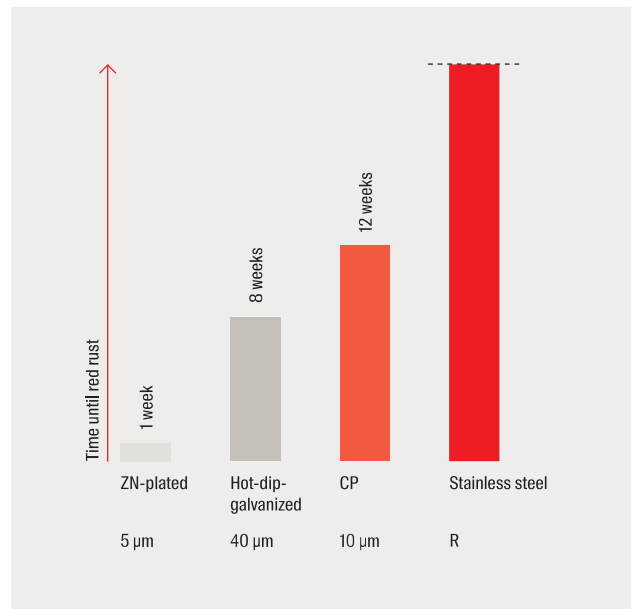

Climate change test (among other things based on Nord-test Method NT)

The climate change test simulates a realistic environment with changing humidity and heat. Here too, the coating of the UltraCut FBS II CP performs significantly better than the usual coatings galvanised zinc-plated (ZN-plated) and hot deep galvanised (HDG).

Advantages and functions

Your advantages at a glance

- The innovative surface coating enables an additional corrosion protection (e.g. through external test reports for the salt spray chamber mist test over 2000 h).
- With up to 3 embedment depths, the UltraCut FBS II allows for the same screw to be used for different component thicknesses.
- The ETA approval covers the application in cracked concrete and the seismic performance categories C1 and C2.
- First concrete screw with an ETA for masonry for a variable field of applications.
- The fischer concrete screw FBS II 8-10 offer the possibility for the ETA compliant application in masonry brick. This grants high security not only in concrete but also in many other applications in other substrates (valid for the base materials solid clay bricks (EN771-1), sand-lime bricks KSL (EN771-2) and solid sand-lime bricks KSV (EN771-2) according to the specification of the ETA-20/0134.

Functioning

- The UltraCut FBS II CP is recommended for the push-through installation.
- The screw is installed correctly when the screw head sits flush on the fixture and cannot be screwed in deeper (visual setting control).
- We recommend using a tangential impact wrench with a suitable impact wrench socket (e.g. fischer FSS 18V) or an internal torx drive.
- The assessment document also covers the use of diamond drilled holes.
- For the installation in masonry, please follow the instruction guidelines in the packaging with the suitable torque setting (impact wrench levels).

Approvals



ETA-15/0352,
for cracked concrete



ETA-20/0134
for masonry



R 120



Seismic C2



According VdS
CES-Guidelines for
sprinkler systems

Recommendations

Suitable for building materials, such as



Cracked concrete



Uncracked concrete



Masonry brick *



Solid sand-lime brick*



Perforated sand-lime
brick*

* ETA recommendation for diameter 8 and 10

Installation and applications

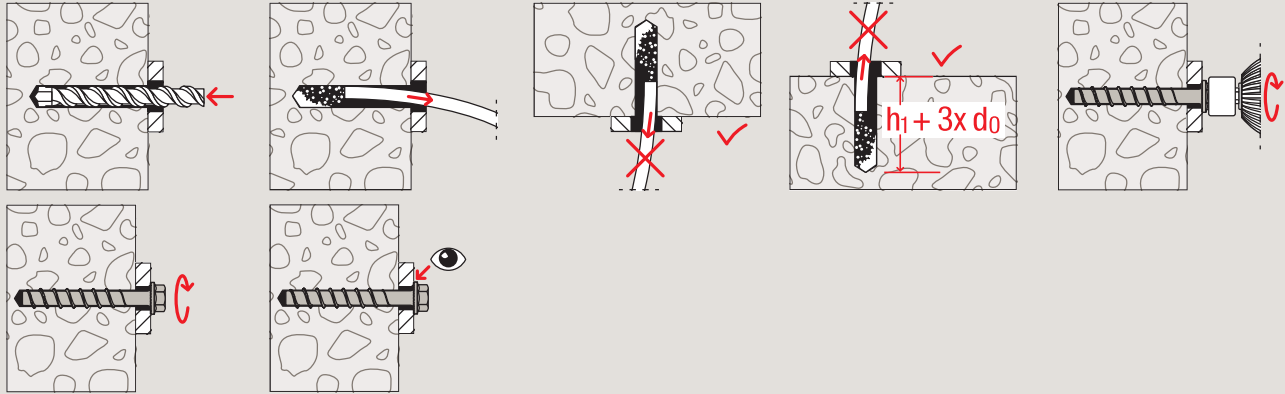

Fixture adjustment

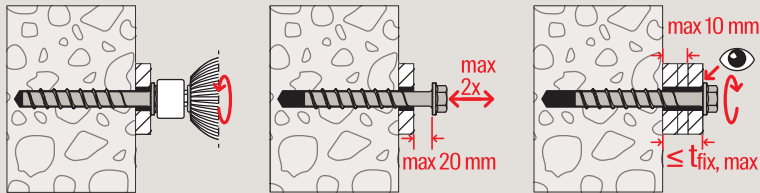

Annular gap filling,

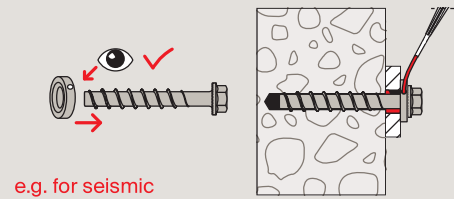

UltraCut FBS II CP

Steel construction



Façade substructures



Connection angle

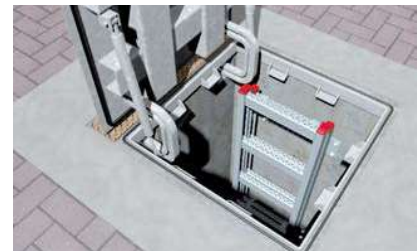

Ladder shafts



Steel girders

fischer PRO. The mobile fixing expert.

www.fischer-international.com

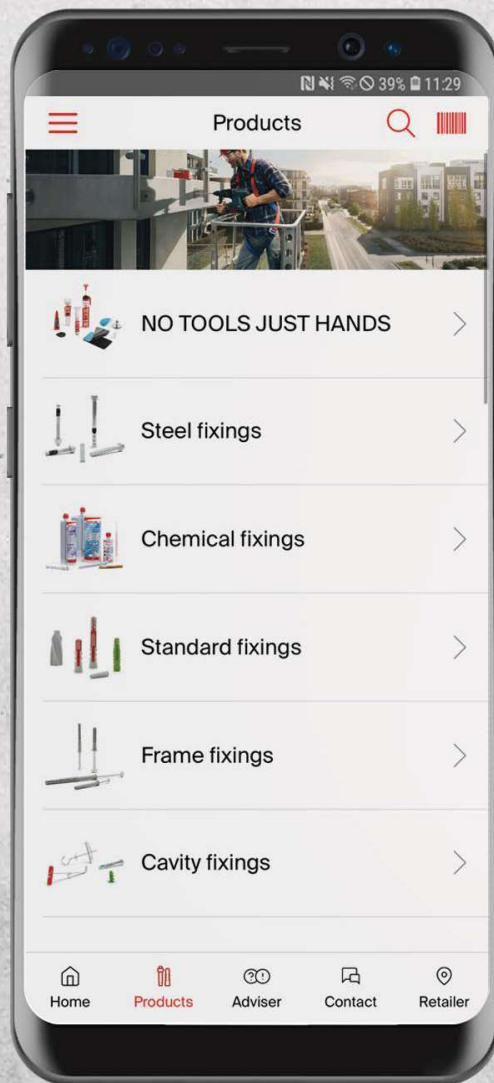

UltraCut FBS II 8, 10 and 12 non-corrosive steel R.

The high-performance concrete screw
for absolute installation ease in the exterior area.

Unique saw-tooth geometry cuts quickly into the concrete – also in reinforced concrete.

The UltraCut FBS II R is available in different head designs. Countersunk (SK) and hexagonal head (US).



UltraCut FBS II 10x100 US R

The specially hardened red tip provides faster and more secure installation.

The short UltraCut FBS II R, with a reduced embedment depth, allows for a short drill hole depth, fast installation and less reinforcement hits.



UltraCut FBS II 10x60 US R



The countersunk head is suitable for visually appealing installations.

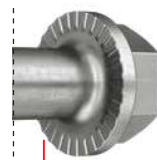

The ribs under the head prevent accidental loosening of the anchor making the system more secure.

Advantages and functions

Your advantages at a glance

- With up to 3 embedment depths, the UltraCut FBS II allows for the same screw to be used for different component thicknesses.
- Expansion-free anchoring (undercut) allows for lowest edge- and axial spacings.
- The assessment (ETA Option 1) covers the use of single-point anchors in cracked and non-cracked concrete.
- The performance categories seismic C1 and C2 ensure that the strictest of safety standards and earthquake specifications can be fulfilled.
- The approved adjustment for the concrete screws allows the screw to be unscrewed twice for a total length of 20 mm, to place maximum 10 mm packing below the base plate head or to align the attached part, and then to tighten the screw again.
- Drill holes do not need to be cleaned during vertical installation (ceiling and floor).
- The fischer concrete screw FBS II 8-10 offer the possibility for the ETA compliant application in masonry brick. This grants high security not only in concrete but also in many other applications in other substrates (valid for the base materials solid clay bricks (EN771-1), sand-lime bricks KSL (EN771-2) and solid sand-lime bricks KSV (EN771-2) according to the specification of the ETA-20/0134.

Functioning

- The UltraCut FBS II R is recommended for the push-through installation.
- The screw is installed correctly when the screw head sits flush on the fixture and cannot be screwed in deeper (visual setting control).
- We recommend using a tangential impact wrench with a suitable impact wrench socket (e.g. fischer FSS 18V) or an internal torx drive.
- The assessment document also covers the use of hollow drill with automatic drill hole cleaning and the use of diamond drilling holes.
- For the installation in masonry, please follow the instruction guidelines in the packaging with the suitable torque setting (impact wrench levels).

Approvals



ETA-15/0352,
for cracked concrete



ETA-20/0134
for masonry



R 120



Seismic C2



According VdS
CES-Guidelines for
sprinkler systems

Recommendations

Suitable for building materials, such as



Cracked concrete



Uncracked concrete



Masonry brick *



Solid sand-lime brick*



Perforated sand-lime
brick*

* ETA recommendation for diameter 8 and 10

Installation and applications

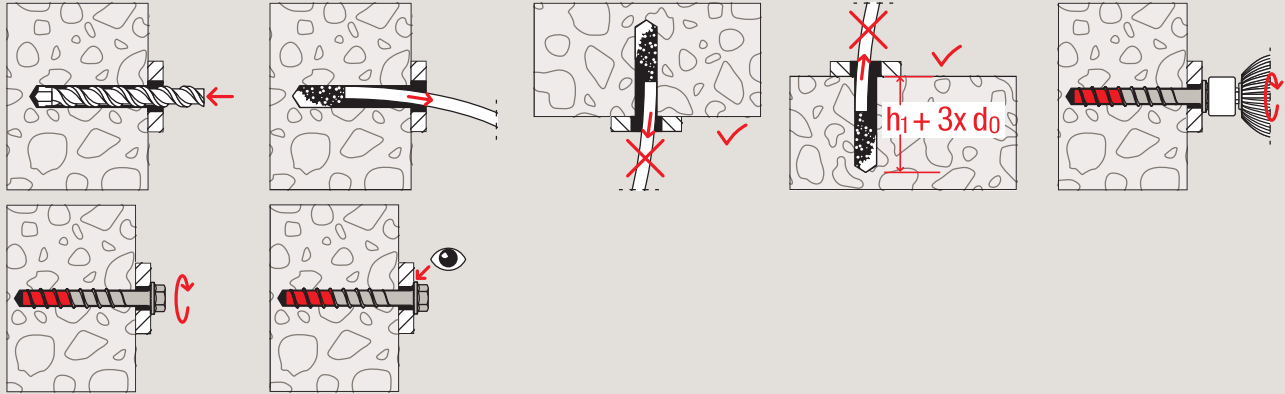

Fixture adjustment

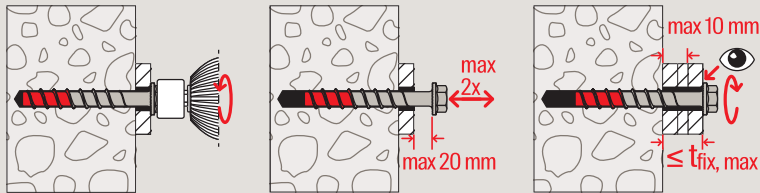

Annular gap filling,

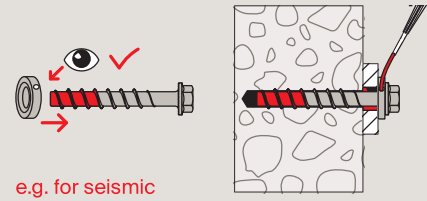

UltraCut FBS II 8, 10 and 12 non-corrosive steel R

Metal construction and outdoor applications



Railings



Brackets / base plates



Canopies



Stadium seating anchoring



Balcony railings



Column footing

Coatings and its base materials

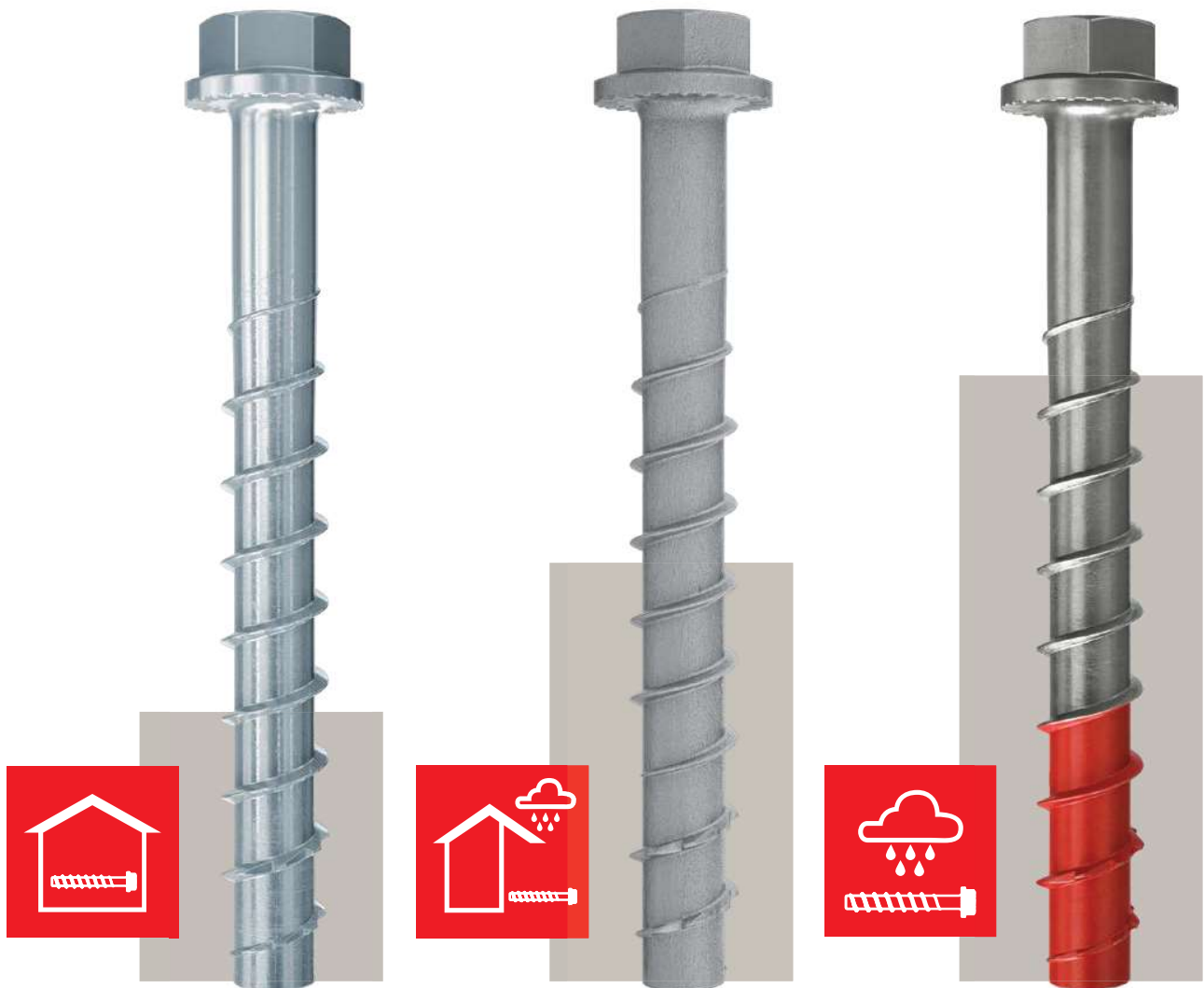

Economic solution: FBS II ZN-plated
Lasting and safe corrosion protection in the dry indoor area. ETA-15/0352 (guarantees a lifetime of 50 years in indoor areas).

The long-lasting one: FBS II CP
Long-lasting coating in comparison with the FBS II ZN-plated (among other things with an external test report for the salt spray chamber mist test of 2.000h).

The extremely durable: FBS II R
Extremely long-lasting and weather-resistant material. The durable solution for the exterior area (ETA 17/0740 guarantees 50 years in the exterior area). Suitable for use in corrosive environments (C3) according to internal technical data from fischer.

UltraCut FBS II 6-10 zinc-plated steel, CP and R in masonry



UltraCut FBS II 6-10 ZN-plated



UltraCut FBS II 8-10 R



UltraCut FBS II 8-10 CP

Approval



ETA-20/0134
for masonry

Your advantages at a glance

- Due to the large ratio between flank and shank diameter, the concrete screw cuts deep into the substrate and ensures low displacement under load.
- The Fischer concrete screws FBS II 6-10 offer the innovative possibility for the ETA compliant application in masonry. This grants high security not only in concrete but also in many other applications in other substrates.
- The concrete screw FBS II 6-10 in zinc-plated steel, special coated CP and stainless steel R has an ETA for masonry brick (EN771-1), solid sand-lime bricks (EN771-2) and perforated sand-lime bricks (EN771-2) according to the specification of the ETA-20/0134.
- The installation of the concrete screw FBS II 6-10 in zinc-plated steel and stainless steel R in masonry brick can be made in the joints not bigger than 3 mm or in plastered substrates also in group.

Applications



TV installation



Radiator

Recommendations

Suitable for building materials, such as



Masonry brick



Solid sand-lime brick



Perforated sand-lime brick

Installation in masonry

UltraCut FBS II 6-10 gvz

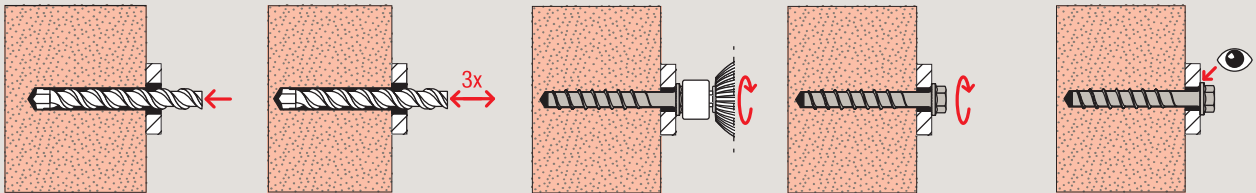

Fixture adjustment

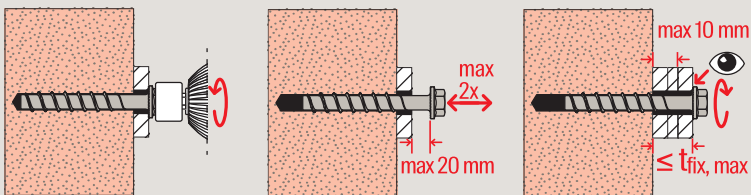

UltraCut FBS II 8-10 R

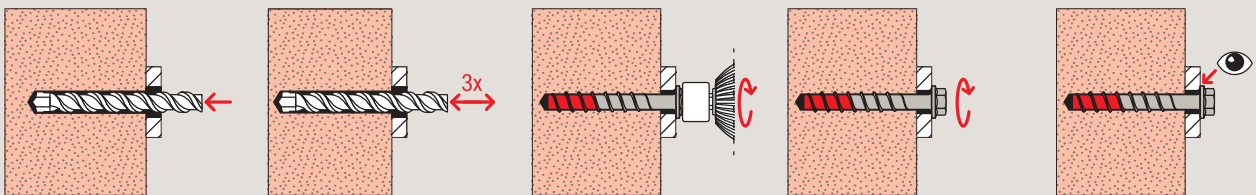

Fixture adjustment

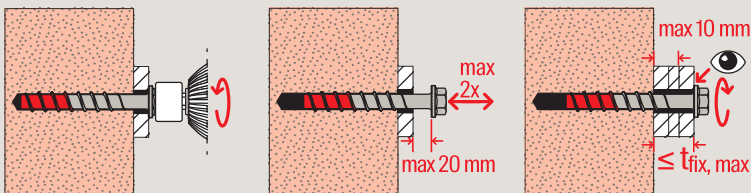

UltraCut FBS II zinc-plated steel as concrete-concrete connector



UltraCut FBS II ZN-plated



Setting tool SC-ST

Your advantages at a glance

- ETA-approval for the fixing of FBS II as a top concrete or concrete-concrete connector for the strengthening of bridges or old buildings.
- Due to the optional setting tool SC-ST the distance of 40 mm to the existing concrete can be easily reached and an ETA-conform, error-free installation of the FBS II is guaranteed.
- Depending on the diameter of the FBS II three embedment depths are possible.

Functioning

- The UltraCut FBS II is mounted with a tangential impact wrench (e.g. the fischer FSS 18V) and the setting tool SC-ST. As soon as the setting tool sits flush to the concrete surface the correct distance is reached and the installation is finally done.

Concrete-concrete connections



Bridge reinforcement



Parking garage reinforcement

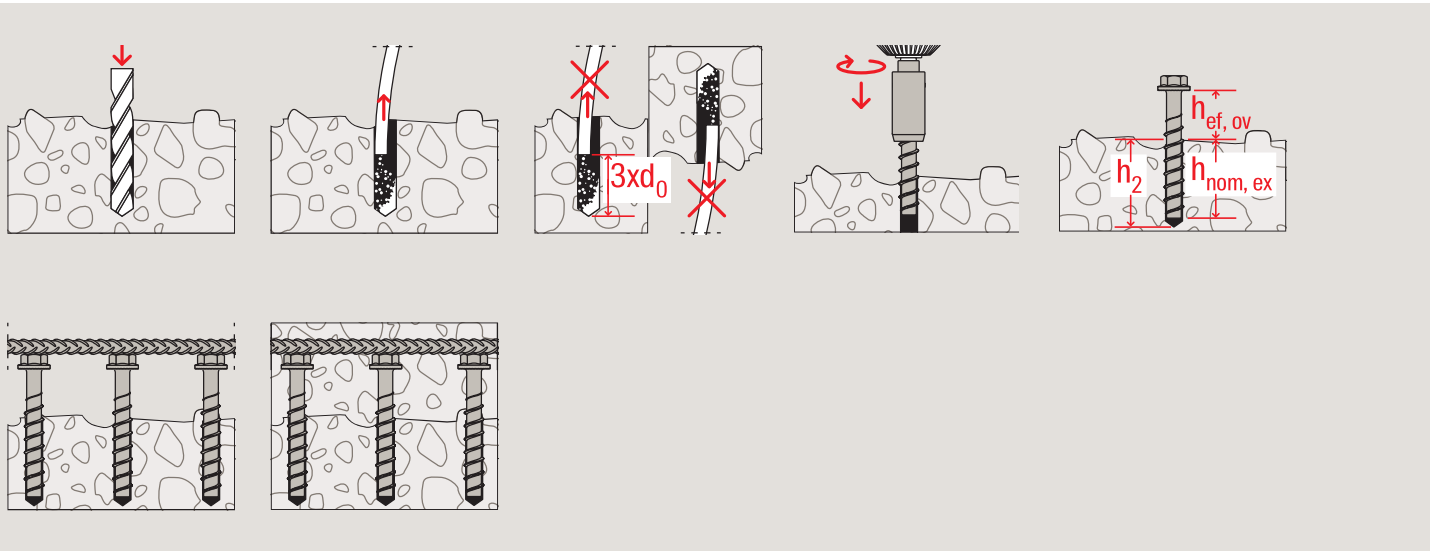

UltraCut FBS II 10 zinc-plated steel with adjusting washer FSW



UltraCut FBS II 10 ZN-plated



Adjusting washer FSW

Your advantages at a glance

- Together with the adjusting disc and the fischer UltraCut FBS II 10 concrete screw wooden beams and wooden sleepers can be adjusted easily and quickly.
- The adjustment process is simplified, so that the support of a second person is not required.
- The adjusting disc is attached to the wooden beam using commonly available screws (recommendation: e.g. fischer PowerFast FPF-PT 5x40, Art. no. 652880).
- After the installation the space under the wood should be injected with mortar.

Functioning

- After the installation of the concrete screw with two adjusting discs FSW the FBS II can easily be loosened, to place maximum 10 mm packing below the wooden beam, and fixed again.
- For installation a tangential impact wrench (e.g. the fischer FSS 18V) with a suitable impact wrench socket or an internal torx drive is recommended.

Timber construction



Wooden sleepers adjustment



Wooden beams adjustment

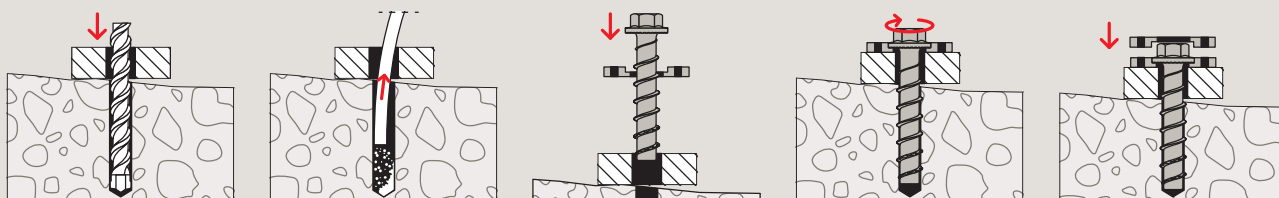

Optional dismantling of the FSW

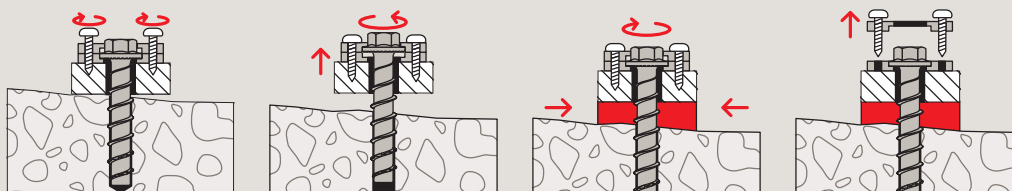

The specialists for concrete screws

Robust die-cast aluminium casing for optimal heat conduction and durability.



FSS 18V 600

Powerful rechargeable battery 4.0 Ah with lithium-ion power and integrated capacity display for checking the charging status.

Brushless motor for smooth and fast assembly process.



FSS 18V 400 BL

The 12 settings allow the torque of the cordless impact wrench to be individually adapted to the application.

Working light for optimum illumination of the working area.

Belt hook for a comfortable transport of the cordless impact wrench.

Compatible battery with all other CAS (Cordless Alliance System) devices.

Compatible battery with all other CAS (Cordless Alliance System) devices.

Cordless Alliance System



Advantages and functions

Advantages at a glance

- The fischer cordless impact wrenches FSS 18V are compatible with all Cordless Alliance System (CAS) chargers and rechargeable batteries worldwide.
- The 12 levels of regulation allow the torque of the cordless impact wrench FSS 18V 400 BL to be individually adapted to the application.
- The brushless motor of the tangential impact wrench FSS 18V 400 BL has an overheat protection that increases safety while reducing downtime and wear.
- The fischer cordless impact wrenches FSS 18V guarantee low vibration despite an extremely high torque.
- The additionally accessories supplied as sockets and checking gauges, enable ease of installation and checking for reusability of the concrete screws FBS II zinc-plated steel.
- The universal fischer service concept offers a seamless repair process worldwide.

Functioning

- The fischer cordless impact wrenches FSS 18V are suitable for the installation of fischer UltraCut concrete screws of all diameters.
- Depending on the head shape of the concrete screw, either an appropriate socket or a special bit TX is recommended for the installation.
- The concrete screw is first screwed in and then tightened by the percussion mechanism.
- If the screw head is in contact with the attachment, correct assembly of the concrete screw is guaranteed (optical setting check).

Concrete screw installation with the fischer cordless impact wrench FSS 18V

The UltraCut FBS II is suitable for push-through installation. For vertical mounting (in ceilings and floor) no drill hole cleaning is necessary, only for drill holes in the floor 3x deeper than the drill hole diameter must be drilled.

In the European Technical Assessment the use of hollow drills (with automatic borehole cleaning) and diamond drilled boreholes are regulated.

For mounting, the fischer cordless impact wrench FSS 18V with corresponding socket or special bit with internal star drive – TX is recommended.

With the screw head resting against the anchor plate surface, so that the screw can no longer be screwed in any further, the correct assembly of the screw is guaranteed (optical setting control).

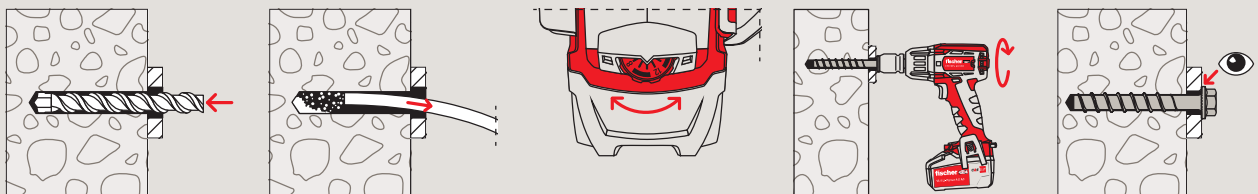

Assortment and technical data

Assortment

Range: Cordless impact wrench FSS 18V 400 BL and FSS 18V 600

FSS Set		FSS 18V 400 BL		FSS 18V 600		FSS-B battery 4.0 Ah		FSS-BC battery charger, air-cooled		Packaging	
Article description	Set	Art.-No	Belt hook FSS BH	Socket [SW]		Checking gauge FUP for concrete screw diameter		Battery 4.0 [Ah]		Battery charger TypeEU	Equipment case, stackable
				10/13/15	15/17/21	8/10	12/14	1x	2x		
FSS 18V 400 BL	Set 1	552922	●	●	–	●	–	–	–	–	●
	Set 2	552924	●	●	–	●	–	●	–	–	●
	Set 3	552926	●	●	–	●	–	–	●	●	●
	Set 4	552928	●	●	–	●	–	●	–	–	●
FSS 18V 600	Set 1	552923	●	–	●	–	●	–	–	–	●
	Set 2	552925	●	–	●	–	●	●	–	–	●
	Set 3	552927	●	–	●	–	●	–	●	●	●
	Set 4	552929	●	–	●	–	●	–	●	–	●

Technical data

Cordless impact wrench FSS 18V 400 BL and FSS 18V 600										
Article description	Battery voltage [V]	Max. idle speed [min]	Max. number of strokes [min]	Max. torque [Nm]	Torque levels	Tool mounting	Vibration impact screws [m/s ²]	Sound power level ³⁾ [dB (A)]	Sound pres- sure level ³⁾ (LwA) [dB (A)]	Weight with battery [kg]
FSS 18V 400 BL	18	0-2150	4250	400	12	Outer squaret 1/2" (12.70 mm)	12 ¹⁾	111	100	1.9
FSS 18V 600	18	0-1600	2200	600	1	Outer squaret 1/2" (12.70 mm)	5.9 ²⁾	107	96	3.1

¹⁾ Measurement uncertainty K → 1.5 m/s²²⁾ Measurement uncertainty K → 5.9 m/s²³⁾ Measurement uncertainty K → 3.0 dB(A)

Assortment & technical data

Battery FSS-B 18V 4.0 Ah and battery charger FSS-BC 12-36V													
Article description	Art.-No	CAS-com- patible	Type of battery	Battery capacity [Ah]	Mains voltage [V]	Mains frequen- cy [Hz]	Max. charge amperage [A]	Mains plug type	Weight of battery [g]	Suitable for battery voltage [V]	Environmental con- ditions		Vibration & shock impact [G]
											Storage & Processing	Air humid- ity	
FSS-B 18V 4.0 Ah	552930 ¹⁾	●	Lithium-Ion	4.0	–	–	–	–	670	–	-20 – +60	< 90	< 5
FSS-BC 12-36V EU	552931 ¹⁾	●	–	–	230 – 240	50 – 60	3	(EU)	–	12 – 36	–	–	–
FSS-BC 12-36V UK	552932 ¹⁾	●	–	–	230 – 240	50 – 60	3	(UK)	–	12 – 36	–	–	–

¹⁾ Battery may only be charged with fischer or CAS chargers.



FiXperience. Safe and reliable.

The fischer design Software FiXperience gives you safe and reliable support in dimensioning your projects whether you are a planner, structural engineer or craftsman. FiXperience is set up modularly

and useable for a variety of applications. The program includes an engineering software with special application modules:



C-FIX

The anchor design program for steel and bonded anchor in concrete, as well as injection systems for masonry. Now with the new FEM design tool for the realistic design of anchorages.



MORTAR-FIX

To determine the injection resin volume for bonded anchors in concrete and masonry.



WOOD-FIX

For the calculation of on-rafter insulation systems and joints in structural timber engineering.



RAIL-FIX

For the design of fixings for railings on reinforced concrete slabs and staircases.



INSTALL-FIX

For the design and dimensioning of MEP installation systems.



FACADE-FIX

For the design of façade fixings with timber sub-structure.



REBAR-FIX

For the design of post-installed rebars in reinforced concrete.



CHANNEL-FIX

For the design of cast-in channels and inserts.



Electronic planner folder

All important documents and records from fischer in one program.

Register on the [myfischer portal](#) to use FiXperience online or download FiXperience for free.

Assortment

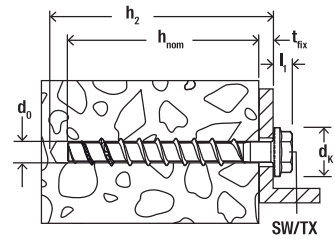

Concrete screw UltraCut FBS II US



FBS II US

FBS II US CP

Item	Galvanized steel Item no.	Corrosion protection coating Item no.	Approval		Drill diameter d_0 [mm]	Screw dimension $d_s \times l_s$ [mm]	Screw-in depth with fixture thickness h_{nom1} / t_{fix} [mm]	Screw-in depth with fixture thickness h_{nom2} / t_{fix} [mm]	Screw-in depth with fixture thickness h_{nom3} / t_{fix} [mm]	Drive	Sales unit [pcs]
			ETA	DIBt							
FBS II 8x55 5/- US TX	536851	557781	●	●	8	10.0 x 55	50 / 5	-	-	TX40 / SW 13	50
FBS II 8x70 20/5 US TX	536852	557782	●	●	8	10.0 x 70	50 / 20	-	65 / 5	TX40 / SW 13	50
FBS II 8x80 30/15 US TX	536853	-	●	●	8	10.0 x 80	50 / 30	-	65 / 15	TX40 / SW 13	50
FBS II 8x80 30/15 US TX	-	557783	●	●	8	10.0 x 80	50 / 30	-	65 / 65	TX40 / SW 13	50
FBS II 8x90 40/25 US TX	536854	557784	●	●	8	10.0 x 90	50 / 40	-	65 / 55	TX40 / SW 13	50
FBS II 8x100 50/35 US TX	536855	557785	●	●	8	10.0 x 100	50 / 50	-	65 / 35	TX40 / SW 13	50
FBS II 8x110 60/45 US TX	536856	-	●	●	8	10.0 x 110	50 / 60	-	65 / 75	TX40 / SW 13	50
FBS II 8x130 80/65 US TX	536857	-	●	●	8	10.0 x 130	50 / 80	-	-	TX40 / SW 13	50
FBS II 8x150 100/85 US TX	558219	-	●	●	8	10.0 x 150	50 / 100	-	65 / 85	TX40 / SW 13	50
FBS II 8x170 120/105 US TX	558220	-	●	●	8	10.0 x 170	50 / 120	-	65 / 105	TX40 / SW 13	50
FBS II 8x190 140/125 US TX	558221	-	●	●	8	10.0 x 190	50 / 140	-	65 / 125	TX40 / SW 13	20
FBS II 10x60 5/-/- US	536858	557786	●	●	10	12.0 x 60	55 / 5	-	-	SW 15	50
FBS II 10x70 15/5/- US	536859	557787	●	●	10	12.0 x 70	55 / 15	65 / 5	-	SW 15	50
FBS II 10x80 25/15/- US	536860	557788	●	●	10	12.0 x 80	55 / 25	65 / 65	-	SW 15	50
FBS II 10x90 35/25/5 US	536861	557789	●	●	10	12.0 x 90	55 / 35	65 / 55	85 / 5	SW 15	50
FBS II 10x100 45/35/15 US	536862	557790	●	●	10	12.0 x 100	55 / 45	65 / 35	85 / 15	SW 15	50
FBS II 10x120 65/55/35 US	536863	557791	●	●	10	12.0 x 120	55 / 65	65 / 25	85 / 35	SW 15	50
FBS II 10x140 85/75/55 US	536864	557792	●	●	10	12.0 x 140	55 / 85	65 / 45	85 / 55	SW 15	50
FBS II 10x160 105/95/75 US	536865	557793	●	●	10	12.0 x 160	55 / 105	65 / 15	85 / 75	SW 15	50
FBS II 10x200 145/135/115 US	536866	-	●	●	10	12.0 x 200	55 / 145	65 / 135	85 / 115	SW 15	20
FBS II 10x230 175/165/145 US	536867	-	●	●	10	12.0 x 230	55 / 175	65 / 165	85 / 145	SW 15	20
FBS II 10x260 205/195/175 US	536868	-	●	●	10	12.0 x 260	55 / 205	65 / 95	85 / 175	SW 15	20
FBS II 10x280 225/215/195 US	558222	-	●	●	10	12.0 x 280	55 / 225	65 / 215	85 / 195	SW 15	20
FBS II 12x70 10/-/- US	536869	-	●	●	12	14.0 x 70	60 / 10	-	-	SW 17	20
FBS II 12x85 25/10/- US	536870	557794	●	●	12	14.0 x 85	60 / 25	75 / 10	-	SW 17	20
FBS II 12x110 50/35/10 US	536871	557795	●	●	12	14.0 x 110	60 / 50	75 / 35	100 / 10	SW 17	20
FBS II 12x130 70/55/30 US	536872	-	●	●	12	14.0 x 130	60 / 70	75 / 55	100 / 30	SW 17	20
FBS II 12x150 90/75/50 US	536873	-	●	●	12	14.0 x 150	60 / 90	75 / 75	100 / 50	SW 17	20
FBS II 12x170 110/95/70 US	558223	-	●	●	12	14.0 x 170	60 / 110	75 / 95	100 / 70	SW 17	20
FBS II 12x190 130/115/90 US	558224	-	●	●	12	14.0 x 190	60 / 130	75 / 115	100 / 90	SW 17	20
FBS II 12x210 150/135/110 US	558225	-	●	●	12	14.0 x 210	60 / 150	75 / 135	100 / 110	SW 17	20
FBS II 14x75 10/-/- US	536874	557796	●	●	14	16.0 x 75	65 / 10	-	-	SW 21	20
FBS II 14x95 30/10/- US	536875	557797	●	●	14	16.0 x 95	65 / 30	85 / 10	-	SW 21	20
FBS II 14x100 35/15/- US	536876	557798	●	●	14	16.0 x 100	65 / 35	85 / 15	-	SW 21	20
FBS II 14x125 60/40/10 US	536877	557799	●	●	14	16.0 x 125	65 / 60	85 / 40	85 / 5	SW 21	10
FBS II 14x150 85/65/35 US	536878	-	●	●	14	16.0 x 150	65 / 85	85 / 65	115 / 35	SW 21	10
FBS II 14x180 115/85/65 US	558226	-	●	●	14	16.0 x 180	65 / 115	85 / 95	115 / 65	SW 21	10
FBS II 14x210 145/125/95 US	558227	-	●	●	14	16.0 x 210	65 / 145	85 / 125	115 / 95	SW 21	10
FBS II 14x240 175/155/125 US	558228	-	●	●	14	16.0 x 240	65 / 175	85 / 155	115 / 125	SW 21	10

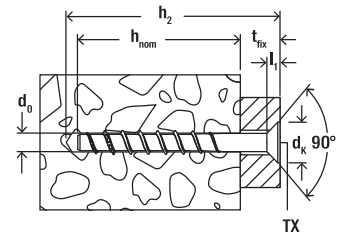

Concrete screw UltraCut FBS II SK



FBS II SK

FBS II SK CP

Item	Galvani- sed steel	Corrosion protection coating	Approval		Drill diameter	Screw dimen- sion	Screw-in depth with fixture thickness	Screw-in depth with fixture thickness	Screw-in depth with fixture thickness	Drive	Sales unit [pcs]
	Item no.	Item no.	ETA	DIBt	d_0 [mm]	$d_s \times l_s$ [mm]	h_{nom1} / t_{fix} [mm]	h_{nom2} / t_{fix} [mm]	h_{nom3} / t_{fix} [mm]		
	gvz	cp									
FBS II 8x60 10/- SK	536880	557800	●	●	8	10.0 x 60	50 / 10	-	-	TX40	50
FBS II 8x80 30/15 SK	536881	-	●	●	8	10.0 x 80	50 / 30	-	65 / 15	TX40	50
FBS II 8x80 30/15 SK	-	557801	●	●	8	10.0 x 80	50 / 30	65 / 65	65 / 15	TX40	50
FBS II 8x90 40/25 SK	536882	-	●	●	8	10.0 x 90	50 / 40	-	65 / 25	TX40	50
FBS II 8x90 40/25 SK	-	557802	●	●	8	10.0 x 90	50 / 40	65 / 55	65 / 25	TX40	50
FBS II 8x100 50/35 SK	558229	-	●	●	8	10.0 x 100	50 / 50	-	65 / 35	TX40	50
FBS II 8x110 60/45 SK	558230	-	●	●	8	10.0 x 110	50 / 60	-	65 / 45	TX40	50
FBS II 8x120 70/55 SK	558231	-	●	●	8	10.0 x 120	50 / 70	-	65 / 55	TX40	50
FBS II 8x140 90/75 SK	558232	-	●	●	8	10.0 x 140	50 / 90	-	65 / 75	TX40	50
FBS II 8x160 110/95 SK	558233	-	●	●	8	10.0 x 160	50 / 110	-	65 / 95	TX40	50
FBS II 8x180 130/115 SK	558234	-	●	●	8	10.0 x 180	50 / 130	-	65 / 115	TX40	20
FBS II 8x200 150/135 SK	558235	-	●	●	8	10.0 x 200	50 / 150	-	65 / 135	TX40	20
FBS II 10x65 10/-/- SK	536884	557803	●	●	10	12.0 x 65	55 / 10	-	-	TX50	50
FBS II 10x80 25/15/- SK	536885	557804	●	●	10	12.0 x 80	55 / 25	65 / 15	-	TX50	50
FBS II 10x95 40/30/10 SK	536886	-	●	●	10	12.0 x 95	55 / 40	65 / 30	85 / 10	TX50	50
FBS II 10x100 45/35/15 SK	536887	557805	●	●	10	12.0 x 100	55 / 45	65 / 35	85 / 15	TX50	50
FBS II 10x120 65/55/35 SK	536888	-	●	●	10	12.0 x 120	55 / 65	65 / 55	85 / 35	TX50	50
FBS II 10x140 85/75/55 SK	558236	-	●	●	10	12.0 x 140	55 / 85	65 / 75	85 / 55	TX50	50
FBS II 10x160 105/95/75 SK	558237	-	●	●	10	12.0 x 160	55 / 105	65 / 95	85 / 75	TX50	50
FBS II 10x180 125/115/95 SK	558238	-	●	●	10	12.0 x 180	55 / 125	65 / 115	85 / 95	TX50	20

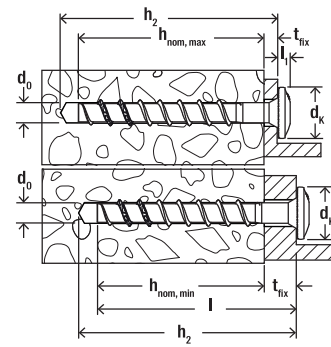

Concrete screw UltraCut FBS II 6



UltraCut FBS II 6 P panhead

UltraCut FBS II 6 SK counter-sunk head

UltraCut FBS II 6 US hexagonal head with molded washer

Item	Item no.	Approval		Drill diameter d_0 [mm]	Min. drill hole depth for through fixings h_2 [mm]	Screw length l_s [mm]	Head-Ø d_k [mm]	Screw-in depth Multiple fixing ETA-18/0242 [mm]	Screw-in depth Single point fixing ETA-15/0352 [mm]	Usable length $t_{fix,min} - t_{fix,max}$ [mm]	Drive	Sales unit [pcs]
		ETA	DIBt									
FBS II 6 x 30/5 P	546377	●	●	6	40	30	14.4	25	-	Screw length - h_{nom}	TX30	100
FBS II 6 x 40/5 P	546378	●	●	6	50	40	14.4	25 - 35	-	Screw length - h_{nom}	TX30	100
FBS II 6 x 40/5 P K (2)	567289	●	●	6	50	40	14.4	25 - 35	-	Screw length - h_{nom}	TX30	1
FBS II 6 x 40/5 LP	546379	●	●	6	50	40	17.5	25 - 35	-	Screw length - h_{nom}	TX30	100
FBS II 6 x 60/5 P	546380	●	●	6	70	60	14.4	25 - 55	40 - 55	Screw length - h_{nom}	TX30	100
FBS II 6 x 60/5 P E	561394	●	●	6	70	60	14.4	25 - 55	40 - 55	Screw length - h_{nom}	TX30	1
FBS II 6 x 80/25 P	546381	●	●	6	90	80	14.4	25 - 55	40 - 55	Screw length - h_{nom}	TX30	100
FBS II 6 x 30/5 SK	546382	●	●	6	40	30	13.5	25	-	Screw length - h_{nom}	TX30	100
FBS II 6 x 40/5 SK	546383	●	●	6	50	40	13.5	25 - 35	-	Screw length - h_{nom}	TX30	100
FBS II 6 x 60/5 SK	546384	●	●	6	70	60	13.5	25 - 55	40 - 55	Screw length - h_{nom}	TX30	100
FBS II 6 x 60/5 SK K (2)	567290	●	●	6	70	60	13.5	25 - 55	40 - 55	Screw length - h_{nom}	TX30	1
FBS II 6 x 80/25 SK	546385	●	●	6	90	80	13.5	25 - 55	40 - 55	Screw length - h_{nom}	TX30	100
FBS II 6 x 100/45 SK	546386	●	●	6	110	100	13.5	25 - 55	40 - 55	Screw length - h_{nom}	TX30	100
FBS II 6 x 120/65 SK	546387	●	●	6	130	120	13.5	25 - 55	40 - 55	Screw length - h_{nom}	TX30	100
FBS II 6 x 140/85 SK	546388	●	●	6	150	140	13.5	25 - 55	40 - 55	Screw length - h_{nom}	TX30	100
FBS II 6 x 160/105 SK	546389	●	●	6	170	160	13.5	25 - 55	40 - 55	Screw length - h_{nom}	TX30	100
FBS II 6 x 40/5 US	558601	●	●	6	50	40	17.0	25 - 35	-	Screw length - h_{nom}	SW 13	100
FBS II 6 x 40/5 US	546390	●	●	6	50	40	17.0	25 - 35	-	Screw length - h_{nom}	SW 10	100
FBS II 6 x 60/5 US	558602	●	●	6	70	60	17.0	25 - 55	40 - 55	Screw length - h_{nom}	SW 13	100
FBS II 6 x 60/5 US	546391	●	●	6	70	60	17.0	25 - 55	40 - 55	Screw length - h_{nom}	SW 10	100
FBS II 6 x 80/25 US	558603	●	●	6	90	80	17.0	25 - 55	40 - 55	Screw length - h_{nom}	SW 13	100
FBS II 6 x 80/25 US	546392	●	●	6	90	80	17.0	25 - 55	40 - 55	Screw length - h_{nom}	SW 10	100
FBS II 6 x 100/45 US	558604	●	●	6	110	100	17.0	25 - 55	40 - 55	Screw length - h_{nom}	SW 13	100
FBS II 6 x 100/45 US	546393	●	●	6	110	100	17.0	25 - 55	40 - 55	Screw length - h_{nom}	SW 10	100
FBS II 6 x 100/45 US E	554072	●	●	6	110	100	17.0	25 - 55	40 - 55	Screw length - h_{nom}	SW 10	1
FBS II 6 x 120/65 US	558605	●	●	6	130	120	17.0	25 - 55	40 - 55	Screw length - h_{nom}	SW 13	100
FBS II 6 x 120/65 US	546394	●	●	6	130	120	17.0	25 - 55	40 - 55	Screw length - h_{nom}	SW 10	100
FBS II 6 x 60/5 US E	554071	●	●	6	-	60	17.0	25 - 55	40 - 55	Screw length - h_{nom}	SW 10	1

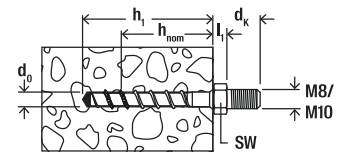
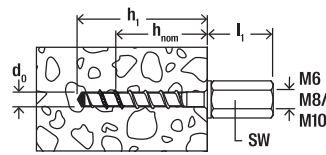

Concrete screw UltraCut FBS II 6 M8/M10

UltraCut FBS II M8/M10
outside threadUltraCut FBS II M6, M8/M10 I
internal thread

Item	Item no.	Approval		Drill diameter d_0 [mm]	Min. drill hole depth for pre-positioned installation h_1 [mm]	Screw length l_s [mm]	Screw-in depth Multiple fixing ETA-18/0242 [mm]	Screw-in depth Single point fixing ETA-15/0352 [mm]	Drive	Sales unit [pcs]
		ETA	DIBt							
FBS II 6 x 25 M8/19	546395	●	●	6	35	25	25	-	SW 10	100
FBS II 6 x 35 M8/19	546396	●	●	6	45	35	35	-	SW 10	100
FBS II 6 x 55 M8/19	546397	●	●	6	65	55	55	55	SW 10	100
FBS II 6 x 35 M10/21	546398	●	●	6	45	35	35	-	SW 13	100
FBS II 6 x 55 M10/21	546399	●	●	6	65	55	55	55	SW 13	100
FBS II 6x35 M6 I	554065	●	●	6	45	35	-	-	SW 13	100
FBS II 6x55 M6 I	554066	●	●	6	65	55	-	55	SW 13	100
FBS II 6 x 35 M8/M10 I	546400	●	●	6	45	35	-	-	SW 13	100
FBS II 6 x 55 M8/M10 I	546401	●	●	6	65	55	-	55	SW 13	100

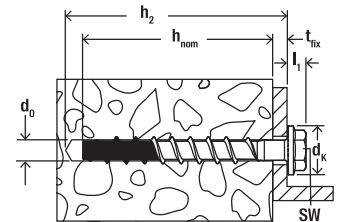

Concrete screw UltraCut FBS II US R



FBS II US R

Item	Item no.	Ap- pro- val ETA	Drill diameter d_0 [mm]	Min. drill hole depth for through fixings h_2 [mm]	Screw dimen- sion $d_s \times l_s$ [mm]	Screw-in depth with fixture thickness h_{nom1} / t_{fix} [mm]	Screw-in depth with fixture thickness h_{nom2} / t_{fix} [mm]	Screw-in depth with fixture thickness h_{nom3} / t_{fix} [mm]	Drive	Sales unit [pcs]
FBS II 8x60 10/- US	543565	●	8	70	10.0 x 60	50 / 10	-	-	SW 13	50
FBS II 8x70 20/5 US	543566	●	8	80	10.0 x 70	50 / 20	-	65 / 5	SW 13	50
FBS II 8x80 30/15 US	543567	●	8	90	10.0 x 80	50 / 30	-	65 / 15	SW 13	50
FBS II 8x90 40/25 US	543568	●	8	100	10.0 x 90	50 / 40	-	65 / 25	SW 13	50
FBS II 8x100 50/35 US	558239	●	8	110	10.0 x 100	50 / 50	-	65 / 35	SW 13	50
FBS II 8x120 70/55 US	558240	●	8	130	10.0 x 120	50 / 70	-	65 / 55	SW 13	50
FBS II 8x140 90/75 US	558241	●	8	150	10.0 x 140	50 / 90	-	65 / 75	SW 13	50
FBS II 8x160 110/95 US	558242	●	8	170	10.0 x 160	50 / 110	-	65 / 95	SW 13	50
FBS II 10x60 5/-/- US	543569	●	10	70	12.0 x 60	55 / 5	-	-	SW 15	50
FBS II 10x70 15/5/- US	543570	●	10	80	12.0 x 70	55 / 15	65 / 5	-	SW 15	50
FBS II 10x80 25/15/- US	543571	●	10	90	12.0 x 80	55 / 25	65 / 15	-	SW 15	50
FBS II 10x90 35/25/5 US	543572	●	10	100	12.0 x 90	55 / 35	65 / 25	85 / 5	SW 15	50
FBS II 10x100 45/35/15 US	543573	●	10	110	12.0 x 100	55 / 45	65 / 35	85 / 15	SW 15	50
FBS II 10x120 65/55/35 US	543574	●	10	130	12.0 x 120	55 / 65	65 / 55	85 / 35	SW 15	50

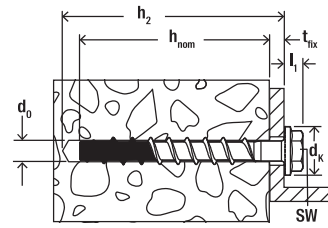

Concrete screw UltraCut FBS II US R



FBS II US R

Item	Item no.	Approval ETA	Drill diameter d_0 [mm]	Min. drill hole depth for through fixings h_2 [mm]	Screw dimension $d_s \times l_s$ [mm]	Screw-in depth with fixture thickness h_{nom1} / t_{fix} [mm]	Screw-in depth with fixture thickness h_{nom2} / t_{fix} [mm]	Screw-in depth with fixture thickness h_{nom3} / t_{fix} [mm]	Drive	Sales unit [pcs]
FBS II 8x60 10/- US	543565	●	8	70	10.0 x 60	50 / 10	-	-	SW 13	50
FBS II 8x70 20/5 US	543566	●	8	80	10.0 x 70	50 / 20	-	65 / 5	SW 13	50
FBS II 8x80 30/15 US	543567	●	8	90	10.0 x 80	50 / 30	-	65 / 15	SW 13	50
FBS II 8x90 40/25 US	543568	●	8	100	10.0 x 90	50 / 40	-	65 / 25	SW 13	50
FBS II 8x100 50/35 US	558239	●	8	110	10.0 x 100	50 / 50	-	65 / 35	SW 13	50
FBS II 8x120 70/55 US	558240	●	8	130	10.0 x 120	50 / 70	-	65 / 55	SW 13	50
FBS II 8x140 90/75 US	558241	●	8	150	10.0 x 140	50 / 90	-	65 / 75	SW 13	50
FBS II 8x160 110/95 US	558242	●	8	170	10.0 x 160	50 / 110	-	65 / 95	SW 13	50
FBS II 10x60 5/-/- US	543569	●	10	70	12.0 x 60	55 / 5	-	-	SW 15	50
FBS II 10x70 15/5/- US	543570	●	10	80	12.0 x 70	55 / 15	65 / 5	-	SW 15	50
FBS II 10x80 25/15/- US	543571	●	10	90	12.0 x 80	55 / 25	65 / 15	-	SW 15	50
FBS II 10x90 35/25/5 US	543572	●	10	100	12.0 x 90	55 / 35	65 / 25	85 / 5	SW 15	50
FBS II 10x100 45/35/15 US	543573	●	10	110	12.0 x 100	55 / 45	65 / 35	85 / 15	SW 15	50
FBS II 10x120 65/55/35 US	543574	●	10	130	12.0 x 120	55 / 65	65 / 55	85 / 35	SW 15	50

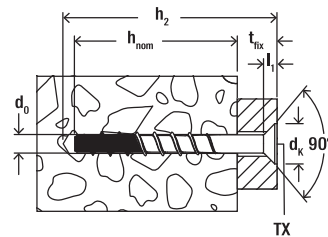

Concrete screw UltraCut FBS II SK R



FBS II SK R

Item	Item no.	Approval ETA	Drill diameter d_0 [mm]	Min. drill hole depth for through fixings h_2 [mm]	Screw dimension $d_s \times l_s$ [mm]	Screw-in depth with fixture thickness h_{nom1} / t_{fix} [mm]	Screw-in depth with fixture thickness h_{nom2} / t_{fix} [mm]	Screw-in depth with fixture thickness h_{nom3} / t_{fix} [mm]	Drive	Sales unit [pcs]
FBS II 8x60 10/- SK	543579	●	8	70	10.0 x 60	50 / 10	-	-	TX40	50
FBS II 8x80 30/15 SK	543580	●	8	90	10.0 x 80	50 / 30	-	65 / 15	TX40	50
FBS II 8x90 40/25 SK	543581	●	8	100	10.0 x 90	50 / 40	-	65 / 25	TX40	50
FBS II 8x100 50/35 SK	558246	●	8	110	10.0 x 100	50 / 50	-	65 / 35	TX40	50
FBS II 10x65 10/-/- SK	543582	●	10	75	12.0 x 65	50 / 10	-	-	TX50	50
FBS II 10x80 25/15/- SK	543583	●	10	90	12.0 x 80	55 / 25	65 / 15	65 / 65	TX50	50
FBS II 10x95 40/30/10 SK	543584	●	10	105	12.0 x 95	55 / 40	65 / 30	85 / 10	TX50	50
FBS II 10x100 45/35/15 SK	543585	●	10	110	12.0 x 100	55 / 45	65 / 35	85 / 15	TX50	50
FBS II 10x120 65/55/35 SK	543586	●	10	130	12.0 x 120	55 / 65	65 / 55	85 / 35	TX50	50

Additional assortment

Complement for UltraCut FBS II



Item	Art.-No.	Internal-Ø [mm]	External-Ø [mm]	Drive	Suitable for UltraCut FBS II [SW/TX]	Sales unit [Stück]
Checking gauge FUP 8	537200	9,9	–	–	FBS II 8	1
Checking gauge FUP 10	537201	12,0	–	–	FBS II 10	1
Checking gauge FUP 12	537202	13,9	–	–	FBS II 12	1
Checking gauge FUP 14	537203	15,6	–	–	FBS II 14	1
Nut SW 10	538577	–	–	1/2"/SW 10	FBS II 6	1
Nut SW 13	538578	–	–	1/2"/SW 13	FBS II 6/FBS II 8	1
Nut SW 15	538579	–	–	1/2"/SW 15	FBS II 10	1
Nut SW 17	538580	–	–	1/2"/SW 17	FBS II 12	1
Nut SW 21	538581	–	–	1/2"/SW 21	FBS II 14	1
Nut 1/2" – 1/4" ¹⁾	553928	–	–	1/2"–1/4"	FBS II 8/FBS II 8 SK + FBS II 6	1
Nut 1/2" – TX50	553929	–	–	1/2"–5/16"	FBS II 10/FBS II 10 SK	1
FMB TX 30 Maxx Bit W5	564314	–	–	TX 30	FBS II 6	5
FMB TX 40 Maxx Bit W 5	564315	–	–	TX 40	FBS II 8/FBS II 8 SK	5
FPB TX50 5/16" ProfiBit	557844	–	–	TX 50	FBS II 10 SK	1
FFD 22x9x6	547515	9	22	–	FBS II 6	4
FFD 26x12x6	538458	12	26	–	FBS II 8	4
FFD 26x12x6 R	541986	12	26	–	FBS II 8 R	4
FFD 30x14x6	538459	14	30	–	FBS II 10/FBS II 12	4
FFD 30x14x6 R	541987	14	30	–	FBS II 10 R/FBS II 12 R	4
FFD 38x19x7	538460	19	38	–	FBS II 14	4
Adjusting washer FSW 10 ²⁾	557276	–	–	–	FBS II 10	40
Setting tool SC-ST 8	557872	–	–	–	FBS II 8 US	1
Setting tool SC-ST 10	557874	–	–	–	FBS II 10 US	1
Washer for FBS II 10	520471	13,5	44	–	FBS II 10	50

¹⁾ Suitable for FMB TX 40 Maxx Bit and FMB TX 30 Maxx Bit

²⁾ Mountable with Power-Fast PPF-PT 5x40 (652880)

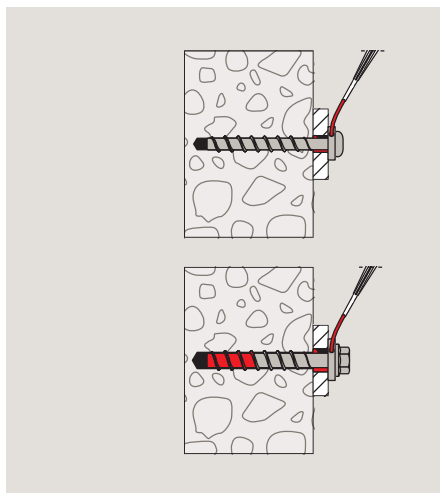

Filling disc for UltraCut FBS II / FBS II CP / FBS II R

By using the backfilling disc, a backlash, e.g. in the case of shear forces, can be ruled out. For this purpose, the filling disc is placed on the concrete screw before installation (recess to the component).

In the next step, the FBS II is screwed in until the filling disc rests against the anchor plate. Now the filling with one of the injection mortars FIS HB, FIS V, FIS SB or FIS EM Plus can be carried out through the lateral bore using the filling aid. The filling quantity depends on the thickness of the anchor plate and the size of the annular gap.

Typical fields of application are brackets, earthquake-approved anchorings

Installation parameters

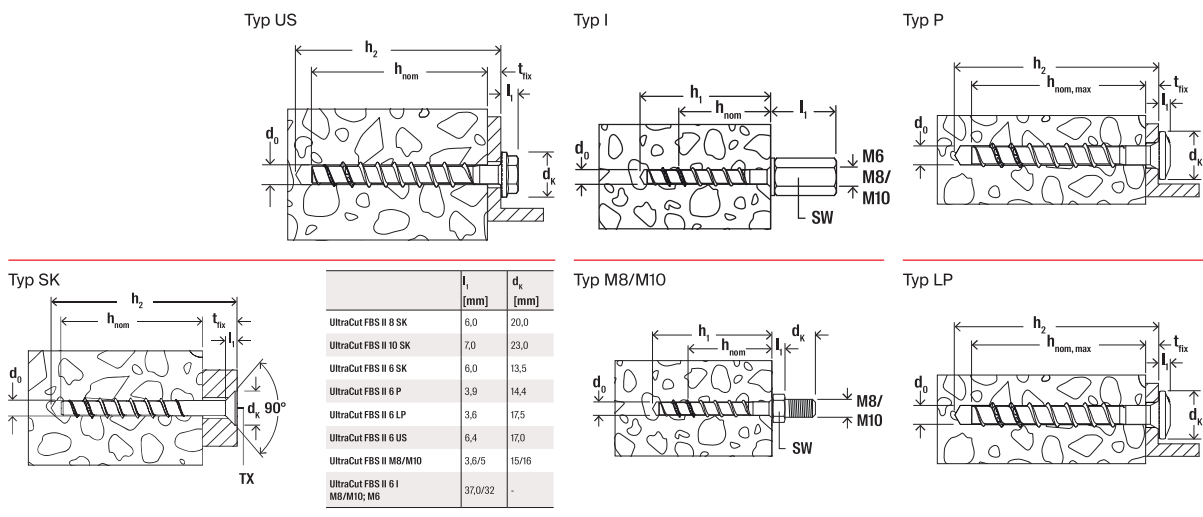

Concrete screw UltraCut FBS II 6-14 zinc-plated steel. / R

Installation parameters concrete

Concrete screw UltraCut FBS II 6-14 zinc-plated steel / R	Drill hole diameter d_0 [mm]	Nominal screw-in depth			Drill hole depth (push- through installation) $h_2 \geq$ [mm]	Clearance hole diam- eter d_1 [mm]	Maximum torque for instal- lation with impact screw driver in concrete ¹⁾		Maximum torque for instal- lation in masonry		Width across flat SW	Drive TX
		h_{nom1} [mm]	h_{nom2} [mm]	h_{nom3} [mm]			$T_{imp, max zinc-platedsteel}$ [Nm]	$T_{imp, max R}$ [Nm]	$T_{imp, max gvz}$ [Nm]	$T_{imp, max R}$ [Nm]		
FBS II 6	6	25-55	25-55	25-55	I + 10	≥ 8	450 ¹⁾	-	-	-	10 ²⁾	TX 30
FBS II 8	8	50	-	65	I + 10	10,6-12	600	450	80	80	13	TX 40 (SK and US)
FBS II 10	10	55	65	85	I + 10	12,8-14	650	450	80	80	15	TX 50 (SK)
FBS II 12	12	60	75	100	I + 10	14,8-16	650	650	-	-	17	-
FBS II 14	14	65	85	115	I + 15	16,9-18	650	-	-	-	21	-

¹⁾ Screw-in depth <35 mm 80 Nm.

²⁾ SW 13 at FBS II ... M10 and FBS II ... M8/M10 I.

³⁾ The values apply to concrete strength of approx. 40 N/mm², for other concrete strength classes the values may differ. The conversion of nominal output into effective tightening torque varies from machine to machine - always therefore use torque control.

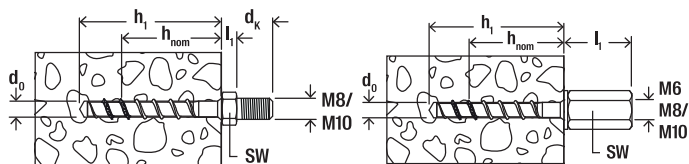

Concrete screw UltraCut FBS II 6

UltraCut FBS II 6 M8/19
hanger boltUltraCut FBS II 6 M6 I; M8/M10 I
connection sleeve

Item	Art.-No.	Ap- proval	Nominal drill-Ø	Minimum drill depth at pre-positioned mode	Screws outer diameter x length	Screwing depth		Width across flat	Sales unit
						Multiple fixing ETA-18/0242	Single fixing ETA-15/0352		
		ETA	d_0 [mm]	h_2 [mm]	[mm]	h_{nom} [mm]	h_{nom} [mm]	[SW]	[pcs]
FBS II 6x25 M8/19	546395	●	6	30	7,5x25	25	–	SW 10	100
FBS II 6x35 M8/19	546396	●	6	40	7,5x35	35	–	SW 10	100
FBS II 6x55 M8/19	546397	●	6	60	7,5x55	55	55	SW 10	100
FBS II 6x35 M10/21	546398	●	6	40	7,5x35	35	–	SW 13	100
FBS II 6x55 M10/21	546399	●	6	60	7,5x55	55	55	SW 13	100
FBS II 6x35 M6 I	554065	●	6	40	7,5x35	35	–	SW 13	100
FBS II 6x55 M6 I	554066	●	6	60	7,5x55	55	55	SW 13	100
FBS II 6x35 M8/M10 I	546400	●	6	40	7,5x35	35	–	SW 13	100
FBS II 6x55 M8/M10 I	546401	●	6	60	7,5x55	55	55	SW 13	100

Optional installation of the fischer concrete screw with an cordless screwdriver.

Possible installation using a standard, high-performance cordless screwdriver if the ideal FSS 18V impact wrench ideal the application is not available.

⚠ ATTENTION Hand twisting is possible or great strain on the wrist will occur!

Advantages:

- No need to purchase additional equipment for a few installations if a cordless screwdriver is already available.
- Lower noise level compared to the impact wrench.

Assembly with cordless screwdriver				
Diameter x screw depth [h_{nom}]	Concrete Grade C 20/25 Installation with new drill	Concrete Grade C 20/25 Installation with used drill	Concrete Grade C 50/60 Installation with new drill	Concrete Grade C 50/60 Installation with used drill
	centre square of drill bit (BEM: 6,25mm)	centre square of drill bit (BEM: 6,25mm)	centre square of drill bit (BEM: 6,25mm)	centre square of drill bit (BEM: 6,25mm)
FBS II 6x25	suitable	suitable	suitable	suitable
FBS II 6x30	suitable	suitable	suitable	suitable
FBS II 6x35	suitable	suitable	suitable	–
FBS II 6x40	suitable	suitable	suitable	–

Loads

Concrete screw UltraCut FBS II US hexagon head with integral washer and FBS II SK countersunk head

Permissible loads of a single anchor¹⁾ in normal concrete of strength class C20/25.

For the design the complete current assessment ETA-15/0352 has to be considered.

Type	Material/ surface	Screw-in depth h_{nom} [mm]	Minimum member thickness h_{min} [mm]	Instal- lation torque $T_{imp, max}^{2)}$ [Nm]	Cracked concrete				Non-cracked concrete			
					Permissible tension (N_{perm}) and shear loads (V_{perm}); minimum spacing (s_{min}) and edge distances (c_{min}) with reduced loads				Permissible tension (N_{perm}) and shear loads (V_{perm}); minimum spacing (s_{min}) and edge distances (c_{min}) with reduced loads			
					$N_{perm}^{3)}$ [kN]	$V_{perm}^{3)}$ [kN]	$s_{min}^{3)}$ [mm]	$c_{min}^{3)}$ [mm]	$N_{perm}^{3)}$ [kN]	$V_{perm}^{3)}$ [kN]	$s_{min}^{3)}$ [mm]	$c_{min}^{3)}$ [mm]
FBS II 6	gvz	40	80	450	1.2	4.3	35	35	3.8	4.3	35	35
	gvz	45	90	450	1.7	4.3	35	35	4.8	4.3	35	35
	gvz	50	90	450	1.9	4.3	35	35	5.7	4.3	35	35
	gvz	55	100	450	2.4	6.3	35	35	6.4	6.3	35	35
FBS II 8	gvz / CP	50	100	600	2.9	4.1	35	35	5.9	5.9	35	35
	gvz / CP	65	120	600	5.7	9.0	35	35	8.8	9.0	35	35
FBS II 10	gvz / CP	55	100	650	4.3	4.6	40	40	6.6	6.6	40	40
	gvz / CP	65	120	650	5.7	11.9	40	40	8.5	14.0	40	40
	gvz / CP	85	140	650	9.2	16.6	40	40	13.1	16.6	40	40
FBS II 12	gvz / CP	60	110	650	5.3	10.6	50	50	7.5	15.1	50	50
	gvz / CP	75	130	650	7.6	15.2	50	50	10.9	15.2	50	50
	gvz / CP	100	150	650	12.0	20.3	50	50	17.1	20.3	50	50
FBS II 14	gvz / CP	65	120	650	5.8	11.6	60	60	8.3	16.6	60	60
	gvz / CP	85	140	650	9.0	18.0	60	60	12.8	22.1	60	60
	gvz / CP	115	180	650	14.7	29.4	60	60	21.0	29.4	60	60

¹⁾ Design according to EN 1992-4:2018 (for static resp. quasi-static loads). The partial safety factors for material resistance as regulated in the ETA as well as a partial safety factor for load actions of $\gamma_L = 1.4$ are considered. As a single anchor counts e.g. an anchor with a spacing $s \geq 3 \times h_{gr}$ and an edge distance $c \geq 1.5 \times h_{gr}$. Accurate data see ETA.

²⁾ Maximum allowable torque for installation with any tangential impact screw driver. Further technical data see ETA.

³⁾ In the case of combinations of tensile and shear loads, bending moments with reduced or minimum spacing and edge distances (anchor groups), the design must be carried out in accordance with the provisions of the complete ETA and the provisions of the EN 1992-4:2018. We recommend using our anchor design software C-FIX.

Concrete screw UltraCut FBS II US R hexagon head with integral washer and FBS II SK R countersunk head

Permissible loads of a single anchor¹⁾ in normal concrete of strength class C20/25.

For the design the complete current assessment ETA-17/0740 has to be considered.

Type	Material/ surface	Screw-in depth h_{nom} [mm]	Minimum member thickness h_{min} [mm]	Maximum installation torque $T_{imp, max}^{2)}$ [Nm]	Cracked concrete				Non-cracked concrete			
					Permissible tension (N_{perm}) and shear loads (V_{perm}); minimum spacing (s_{min}) and edge distances (c_{min}) with reduced loads				Permissible tension (N_{perm}) and shear loads (V_{perm}); minimum spacing (s_{min}) and edge distances (c_{min}) with reduced loads			
					$N_{perm}^{3)}$ [kN]	$V_{perm}^{3)}$ [kN]	$s_{min}^{3)}$ [mm]	$c_{min}^{3)}$ [mm]	$N_{perm}^{3)}$ [kN]	$V_{perm}^{3)}$ [kN]	$s_{min}^{3)}$ [mm]	$c_{min}^{3)}$ [mm]
FBS II 8	R	50	100	450	1.9	4.1	35	35	3.3	5.9	35	35
FBS II 8	R	65	120	450	4.3	6.1	35	35	6.7	8.8	35	35
FBS II 10	R	55	100	450	2.1	4.6	40	40	4.0	6.6	40	40
FBS II 10	R	65	120	450	2.9	6.0	40	40	6.7	8.5	40	40
FBS II 10	R	85	140	450	7.6	18.4	40	40	13.1	20.9	40	40
FBS II 12	R	60	110	650	2.1	5.3	50	50	4.8	7.5	50	50
FBS II 12	R	75	130	650	5.2	15.2	50	50	5.7	21.8	50	50
FBS II 12	R	100	150	650	12.0	23.9	50	50	17.1	26.2	50	50

¹⁾ Design according to EN 1992-4:2018 (for static resp. quasi-static loads). The partial safety factors for material resistance as regulated in the ETA as well as a partial safety factor for load actions of $\gamma_L = 1.4$ are considered. As a single anchor counts e.g. an anchor with a spacing $s \geq 3 \times h_{gr}$ and an edge distance $c \geq 1.5 \times h_{gr}$. Accurate data see ETA.

²⁾ Maximum allowable torque for installation with any tangential impact screw driver. Further technical data see ETA.

³⁾ In the case of combinations of tensile and shear loads, bending moments with reduced or minimum spacing and edge distances (anchor groups), the design must be carried out in accordance with the provisions of the complete ETA and the provisions of the EN 1992-4:2018. We recommend using our anchor design software C-FIX.

Loads

Concrete screw UltraCut FBS II

Recommended loads¹⁾³⁾ for a single anchor or a fixing point⁴⁾⁵⁾⁶⁾ in solid brick masonry.

Type			FBS II 8	FBS II 10
Anchorage depth	h_{nom}	[mm]	65	85
Recommended loads (F) in the respective base material ²⁾³⁾				
Solid clay brick (EN771-1) $\geq 240 \times 113 \times 115$ mm	$f_b \geq 12$	[kN]	1.1 ¹⁰⁾	1.4 ¹⁰⁾
Solid clay brick (EN771-1) $\geq 240 \times 113 \times 115$ mm	$f_b \geq 20$	[kN]	1.6 ⁷⁾¹⁰⁾	1.6 ⁷⁾¹⁰⁾
Solid sand-lime brick (EN771-2) $\geq 240 \times 71 \times 115$ mm	$f_b \geq 12$	[kN]	1.2 ⁷⁾¹⁰⁾	1.2 ⁷⁾¹⁰⁾
Aerated concrete (EN771-4) $\geq 499 \times 249 \times 120$ mm	$f_b \geq 6$	[kN]	0.7	0.9
Minimum spacing (s_{min}) and edge distances (c_{min})				
Minimum spacing within anchor groups of 2 or 4 anchors	s_{min}	[mm]	80	80
Minimum spacing between single anchors or anchor groups	s_{min}	[mm]	80	80
Minimum distance to the horizontal joint	$c_{min,v}^{8)}$	[mm]	20	20
Minimum distance to the vertical joint	$c_{min,h}^{8)}$	[mm]	40	40
Minimum distance to the free edge	$c_{min,free\ edge}^{8)}$	[mm]	200	200
Tightening torque ⁹⁾ ($T_{tighten}$) in respective base material				
Solid clay brick ¹⁰⁾	$T_{tighten}$	[Nm]	10	10
Solid sandlime brick ¹⁰⁾	$T_{tighten}$	[Nm]	15	15
Aerated concrete	$T_{tighten}$	[Nm]	5	5

¹⁾ An appropriate safety factor is considered.

²⁾ The given loads apply to the given brick measures for masonry with superimposed load. Larger brick formats are at least equivalent in case of the loads. Base material f_b in [N/mm²].

³⁾ The loads only apply to multiple fixings of non-load-bearing systems and are valid for tensile load, shear load and oblique load under any angle.

⁴⁾ To confirm the given technical data, it is recommended to carry out tests on the construction site. In case of not visible joints a 100% testing of the anchors is recommended as the concrete screws only work in the brick but not in mortar joints.

⁵⁾ A fixing point can be a single anchor, 2 anchors or 4 anchors with a minimum spacing s_{min} . Anchor groups of 4 anchors are arranged in rectangular disposition.

⁶⁾ The fixing points have to be arranged in this way that there will be always maximum one fixing point arranged in one brick.

⁷⁾ Brick pull-out is decisive.

⁸⁾ The values $c_{min,v}$ and $c_{min,h}$ are only valid if the mortar joints are filled proper. Otherwise the joints has to be considered as free edges and $c_{min,free\ edge}$ is decisive. Minimum mortar strenght is M 2.5.

⁹⁾ The screw is screwed in with a cordless screwdriver, an impact screwdriver or by hand. The screwing process must be finished immediately when the screw head is in contact with the assembled object. The specified tightening torque must then be applied with a torque wrench.

¹⁰⁾ The values are valid for unperforated solid bricks.

Concrete screw UltraCut FBS II for temporary fastening

Permissible loads of a single anchor¹⁾ in normal concrete of strength class C20/25 to C50/60.

For the design the complete current assessment Z-21.8-2049 has to be considered.

Type	Material/ surface	Screw-in depth h_{nom} [mm]	Minimum member thickness h_{min} [mm]	Maximum installation torque $T_{imp,max}^{2)}$ [Nm]	Minimum spacing (s_{min}) and edge distances (c_{min})		Cracked and non-cracked concrete			
					s_{min} [mm]	$c_{min}^{3)}$ [mm]	Permissible load $F_{perm}^{4)}$			
							$f_{c,cube} \geq 10$ N/mm ² [kN]	$f_{c,cube} \geq 15$ N/mm ² [kN]	$f_{c,cube} \geq 20$ N/mm ² [kN]	$f_{c,cube} \geq 25$ N/mm ² [kN]
FBS II 8	gvz	50	100	400	200	65	1.9	2.3	2.6	2.9
	gvz	65	150	400	300	100	3.6	4.4	5.1	5.6
FBS II 10	gvz	55	105	400	210	70	2.2	2.7	3.1	3.5
	gvz	65	130	400	260	85	2.9	3.5	4.1	4.5
	gvz	85	205	650	410	135	5.8	7.1	8.1	9.1
FBS II 12	gvz	60	120	400	240	80	2.8	3.4	3.9	4.4
	gvz	75	150	400	300	100	4.0	4.9	5.6	6.1
	gvz	100	240	650	480	160	7.6	9.3	10.8	12.0
FBS II 14	gvz	65	115	400	230	75	2.3	2.8	3.2	3.6
	gvz	85	150	400	300	100	3.6	4.4	5.0	5.6
	gvz	115	255	650	510	170	8.9	10.9	12.6	14.0

¹⁾ Material safety factor as well as a partial safety factor for load actions of $\gamma_L = 1.4$ is considered. The screw may be used in the concrete member before the characteristic compressive strength $f_{ck,cube}$ is reached. In this case, the concrete compressive strength $f_{c,cube}$ must have reached a value of at least 10 N/mm². Only intended for temporary use and one-time screwing into the same drill hole. Conditions for reuse of the screw see, approval.

²⁾ Values for impulse wrenches with tangential impact and automatic stop device.

³⁾ In case of combined action of shear load and installation close to the edge, the edge distance must be $\geq c_{min} \times 1.5$. Detail see approval.

⁴⁾ Values valid for all load directions.

Loads

Concrete screw UltraCut FBS II 6

Permissible loads for a single anchor¹⁾ for multiple use of redundant non-structural applications* in normal concrete C20/25.

For the design the complete current assessment ETA - 18/0242 has to be considered.

Type	Material/ surface	Screw-in depth h_{nom} [mm]	Minimum member thickness h_{min} [mm]	Maximum installation torque $T_{inst,max}^{2)}$ [Nm]	Cracked concrete				Non-cracked concrete			
					Permissible tension (N_{perm}) and shear loads (V_{perm}); minimum spacing (s_{min}) and edge distances (c_{min}) with reduced loads				Permissible tension (N_{perm}) and shear loads (V_{perm}); minimum spacing (s_{min}) and edge distances (c_{min}) with reduced loads			
					$N_{perm}^{3)}$ [kN]	$V_{perm}^{3)}$ [kN]	$s_{min}^{3)}$ [mm]	$c_{min}^{3)}$ [mm]	$N_{perm}^{3)}$ [kN]	$V_{perm}^{3)}$ [kN]	$s_{min}^{3)}$ [mm]	$c_{min}^{3)}$ [mm]
FBS II 6	gvz	25	80	≤ 5	0.7	1.8	35	35	1.4	2.3	35	35
	gvz	30	80	≤ 5	1.2	2.3	35	35	2.4	2.3	35	35
	gvz	35	80	≤ 5	1.7	4.3	35	35	3.1	4.3	35	35
	gvz	40	80	≤ 10	2.4	4.3	35	35	3.8	4.3	35	35
	gvz	45	90	≤ 10	2.9	4.3	35	35	4.8	4.3	35	35
	gvz	50	90	≤ 10	3.6	4.3	35	35	5.7	4.3	35	35
	gvz	55	100	≤ 10	4.0	6.3	35	35	6.4	6.3	35	35

* In addition to the load table above, the following must be considered for multiple fastening of non-structural redundant systems:

A multiple fixing (redundant system) according to EN 1992-4 and CEN/TR 17079 is defined by

- at least 3 fixing points (per attached element) with at least one anchor at each fixing point and a permissible load per fixing point of 1.4 kN

- or by at least 4 fixing points with at least one anchor each fixing point and a permissible load per fixing point of 2.1 kN

- Additionally, it has to be proven that the stiffness of the attached element shall be large enough to ensure that in case of excessive slip or failure of a fastener the load on this fastener or fixing point can be transferred to neighbouring fixing points without significantly violating the requirements on the attached element in the serviceability and ultimate limit state.

For further details see EN 1992-4 section 7.3 and CEN/TR 17079.

¹⁾ Design according to EN 1992-4:2018 (for static resp. quasi-static loads). The partial safety factors for material resistance as regulated in the ETA as well as a partial safety factor for load actions of $\gamma_L = 1.4$ are considered.

²⁾ Further technical information for installation see ETA.

³⁾ In the case of combinations of tensile and shear loads, bending moments with reduced or minimal edge and axial spacings (anchor groups), the design must be carried out in accordance with the provisions of the complete ETA and the provisions of the EN 1992-4:2018.

Concrete screw UltraCut FBS II 6

Permissible loads for a single anchor¹⁾ for multiple use of redundant non-structural applications* in pre-stressed hollow-core concrete slabs of concrete strength C30/37.

For the design the complete current assessment ETA - 18/0242 has to be considered.

Type			FBS II 6 gvz						
Screw-in depth		h_{nom}	25	30	35	40	45	50	55
Permissible load $F_{perm}^{3)}$ in the respective bottom flange thickness									
$d_b \geq 25$ mm		[kN]	0.2	0.5	0.5	0.5	0.5	0.5	0.5
$d_b \geq 30$ mm		[kN]	1.7	1.7	1.7	1.7	1.7	1.7	1.7
$d_b \geq 35$ mm		[kN]	1.7	1.9	2.1	2.4	2.6	2.9	3.1
$d_b \geq 40$ mm		[kN]	1.7	2.3	2.6	2.9	3.3	3.6	3.8
$d_b \geq 50$ mm		[kN]	1.7	2.3	3.3	3.8	4.3	4.3	5.7
Installation torque	$T_{inst,max}$	[Nm]	5.0	5.0	10	10	10	10	10
Minimum spacing	$s_{1,8/22}$	[mm]	100	100	100	100	100	100	100
Minimum edge distance	$c_{1,2}$	[mm]	100	100	100	100	100	100	100

* In addition to the load table above, the following must be considered for multiple fastening of non-structural redundant systems:

A multiple fixing (redundant system) according to EN 1992-4 and CEN/TR 17079 is defined by

• at least 3 fixing points (per attached element) with at least one anchor at each fixing point and a permissible load per fixing point of 1.4 kN

• or by at least 4 fixing points with at least one anchor each fixing point and a permissible load per fixing point of 2.1 kN

• Additionally, it has to be proven that the stiffness of the attached element shall be large enough to ensure that in case of excessive slip or failure of a fastener the load on this fastener or fixing point can be transferred to neighbouring fixing points without significantly violating the requirements on the attached element in the serviceability and ultimate limit state.

For further details see EN 1992-4 section 7.3 and CEN/TR 17079.

¹⁾ Design according to EN 1992-4:2018 (for static resp. quasi-static loads). The partial safety factors for material resistance as regulated in the ETA as well as a partial safety factor for load actions of $\gamma_L = 1.4$ are considered.

²⁾ Further technical information for installation see ETA.

³⁾ Valid for tensile load, shear load and oblique load under any angle. In the case of combinations of tensile, shear loads and bending moments, the design must be carried out in accordance with the provisions of the complete ETA and the provisions of the EN 1992-4:2018.

Loads

Concrete screw UltraCut FBS II US/SK

Permissible loads¹⁾²⁾ for a single anchor in masonry for Push-through installation.
For the design the complete current assessment ETA-20/0134 of 14.07.2022 has to be considered.

Type	Min. compressive brick strength	Brick raw density	Minimum brick dimensions	Nominal anchorage depth	Minimum member thickness	Maximum installation torque	Permissible tensile load ⁴⁾	Permissible shear load ⁴⁾ parallel ⁶⁾	Minimum spacing ⁵⁾	Minimum edge distance ⁵⁾
	f_b [N/mm ²]	ρ [kg/dm ³]	(L x W x H) [mm]	h_{nom} [mm]	h_{min} [mm]	$T_{imp,max}^{3)}$ [Nm]	N_{perm} [kN]	$V_{perm(\parallel)}$ [kN]	$s_{min(\square)} / s_{min(\square)}$ [mm]	c_{min} [mm]
Solid brick Mz, acc. to EN 771-1										
FBS II 6	≥ 12,0	≥ 1,8	240 x 115 x 71	≥ 40	≥ 115	80	0.54	0.34	80	50
FBS II 6	≥ 16,0	≥ 1,8	240 x 115 x 71	≥ 40	≥ 115	80	0.60	0.40	80	50
FBS II 6	≥ 17,5	≥ 1,8	240 x 115 x 71	≥ 40	≥ 115	80	0.66	0.40	80	50
FBS II 8	≥ 12,0	≥ 1,8	240 x 115 x 71	≥ 50	≥ 115	80	0.46	1.37	80	60
FBS II 8	≥ 16,0	≥ 1,8	240 x 115 x 71	≥ 50	≥ 115	80	0.54	1.60	80	60
FBS II 8	≥ 17,5	≥ 1,8	240 x 115 x 71	≥ 50	≥ 115	80	0.57	1.66	80	60
FBS II 10	≥ 12,0	≥ 1,8	240 x 115 x 71	≥ 55	≥ 115	80	0.40	1.26	80	70
FBS II 10	≥ 16,0	≥ 1,8	240 x 115 x 71	≥ 55	≥ 115	80	0.46	1.46	80	70
FBS II 10	≥ 17,5	≥ 1,8	240 x 115 x 71	≥ 55	≥ 115	80	0.49	1.51	80	70
Solid brick Mz, nordic, acc. to EN 771-1										
FBS II 6	≥ 16,0	≥ 1,8	228 x 108 x 54	≥ 40	≥ 108	80	0.34	0.31	80	50
FBS II 6	≥ 20,0	≥ 1,8	228 x 108 x 54	≥ 40	≥ 108	80	0.40	0.37	80	50
FBS II 8	≥ 16,0	≥ 1,8	228 x 108 x 54	≥ 50	≥ 108	80	0.46	1.34	80	60
FBS II 8	≥ 20,0	≥ 1,8	228 x 108 x 54	≥ 50	≥ 108	80	0.51	1.49	80	60
FBS II 10	≥ 16,0	≥ 1,8	228 x 108 x 54	≥ 55	≥ 108	80	0.37	1.23	80	70
FBS II 10	≥ 20,0	≥ 1,8	228 x 108 x 54	≥ 55	≥ 108	80	0.43	1.37	80	70
Solid sand-lime brick KS, acc. to EN 771-2										
FBS II 6	≥ 12,0	≥ 1,8	240 x 115 x 71	≥ 40	≥ 115	80	0.43	0.51	80	50
FBS II 6	≥ 16,0	≥ 1,8	240 x 115 x 71	≥ 40	≥ 115	80	0.49	0.60	80	50
FBS II 6	≥ 20,0	≥ 1,8	240 x 115 x 71	≥ 40	≥ 115	80	0.54	0.66	80	50
FBS II 8	≥ 12,0	≥ 1,8	240 x 115 x 71	≥ 50	≥ 115	80	0.54	0.66	80	60
FBS II 8	≥ 16,0	≥ 1,8	240 x 115 x 71	≥ 50	≥ 115	80	0.60	0.74	80	60
FBS II 8	≥ 20,0	≥ 1,8	240 x 115 x 71	≥ 50	≥ 115	80	0.69	0.83	80	60
FBS II 10	≥ 12,0	≥ 1,8	240 x 115 x 71	≥ 55	≥ 115	80	0.54	0.89	80	70
FBS II 10	≥ 16,0	≥ 1,8	240 x 115 x 71	≥ 55	≥ 115	80	0.63	1.00	80	70
FBS II 10	≥ 20,0	≥ 1,8	240 x 115 x 71	≥ 55	≥ 115	80	0.69	1.11	80	70
Perforated sand-lime brick KSL, acc. to EN 771-2										
FBS II 6	≥ 10,0	≥ 1,4	240 x 175 x 113	≥ 40	≥ 175	65	0.09	0.80	80	50
FBS II 6	≥ 12,0	≥ 1,4	240 x 175 x 113	≥ 40	≥ 175	65	0.11	0.94	80	50
FBS II 6	≥ 16,0	≥ 1,4	240 x 175 x 113	≥ 40	≥ 175	65	0.14	1.17	80	50
FBS II 6	≥ 17,5	≥ 1,4	240 x 175 x 113	≥ 40	≥ 175	65	0.17	1.26	80	50
FBS II 8	≥ 10,0	≥ 1,4	240 x 175 x 113	≥ 50	≥ 175	65	0.26	0.66	80	60
FBS II 8	≥ 12,0	≥ 1,4	240 x 175 x 113	≥ 50	≥ 175	65	0.29	1.03	80	60
FBS II 8	≥ 16,0	≥ 1,4	240 x 175 x 113	≥ 50	≥ 175	65	0.37	1.40	80	60
FBS II 8	≥ 17,5	≥ 1,4	240 x 175 x 113	≥ 50	≥ 175	65	0.40	1.49	80	60
FBS II 10	≥ 10,0	≥ 1,4	240 x 175 x 113	≥ 55	≥ 175	65	0.23	0.77	80	70
FBS II 10	≥ 12,0	≥ 1,4	240 x 175 x 113	≥ 55	≥ 175	65	0.26	1.23	80	70
FBS II 10	≥ 16,0	≥ 1,4	240 x 175 x 113	≥ 55	≥ 175	65	0.34	1.66	80	70
FBS II 10	≥ 17,5	≥ 1,4	240 x 175 x 113	≥ 55	≥ 175	65	0.37	1.77	80	70

¹⁾ The partial safety factors for material resistance as regulated in assessment as well as a partial safety factor for load actions of $\gamma_t = 1.4$ are considered. Load values are valid for zinc-plated steel all sizes and head shapes, for stainless steel R for the sizes 8 and 10. Exakt values see ETA.

²⁾ The given loads are valid for installation and use of fixations in dry masonry, use category d/d, width of the joints $w_j \leq 3$ mm and general purpose mortar with strength class M2.5 -M9. Further information and details on drill hole preparation, etc., see ETA.

³⁾ Maximum allowable device torque for installation with any tangential impact screw driver. Further technical data see ETA.

⁴⁾ In the case of combinations of tensile and shear loads, bending moments and reduced edge and axial spacings (anchor groups), the design must be carried out in accordance with the provisions of the complete assessment.

⁵⁾ Minimum feasible spacing resp. edge distance. Details as well as to the distances to joints see assessment.

⁶⁾ Shear load parallel to the vertical joint. Load reduction for shear load perpendicular to the vertical joint see ETA.

Dealer:

www.fischer-international.com



fischer stands for

Fixing Systems
Automotive
fischertechnik
Consulting
Electronic Solutions

fischerwerke GmbH & Co. KG
Klaus-Fischer-Straße 1 · 72178 Waldachtal
Germany
T +49 7443 12 - 0
www.fischer-international.com · info@fischer.de
